

# Owner's Manual

Pro, Deluxe, & Enhanced Systems

2026 Model Year

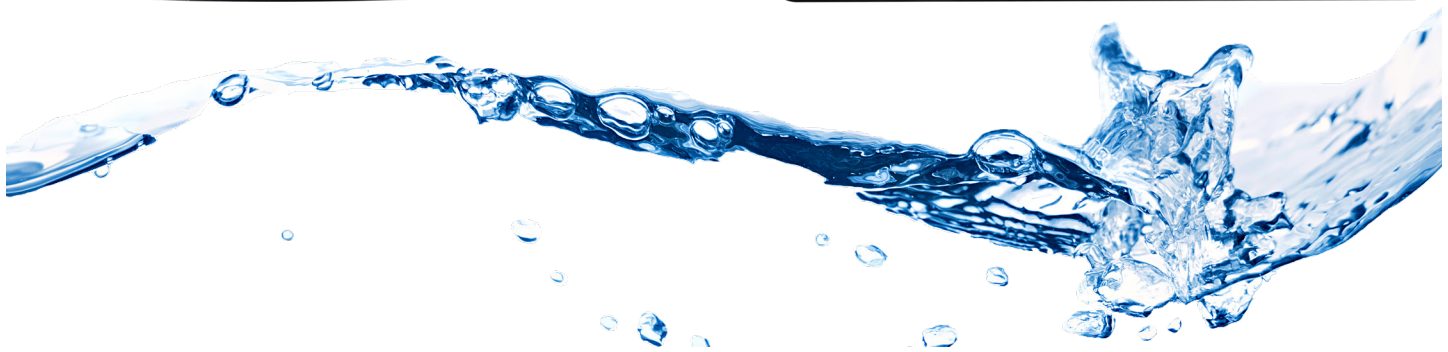

[CrusaderWater.com](http://CrusaderWater.com)

This page is intentionally left blank.

---

# Table of Contents

---

System Features and Benefits.....	Page 5
System Components.....	Page 6
Your Responsibilities as an Equipment Owner.....	Page 9
Cleaning and Disinfecting Your System with ProGuard.....	Page 10
Recommended Cleaning & Disinfection Schedule.....	Page 11
System Control & Operation.....	Page 12
Understanding How Your System Operates.....	Page 14
Warnings and System Operational Requirements.....	Page 17
System Installation and Start-up Guidelines & Checklist.....	Page 18
General Warnings & Installation Instructions.....	Page 20
System Programming.....	Page 25
Placing Unit Into Service.....	Page 27
Parts Diagrams.....	Page 28
Service Instructions.....	Page 39
System Troubleshooting Guidelines.....	Page 43
Error Codes.....	Page 47
Limited Lifetime Warranty Information.....	Page 49
How Much Money Can Soft Water Save You?.....	Page 50

# **This Product is Made with Pride in the United States of America**



Each valve is tested and certified by the WQA to NSF/ANSI Standard 61 for material safety and structural integrity and lead free compliance as well as CSA B483.1.

**[www.CrusaderWater.com](http://www.CrusaderWater.com)**

---

# System Features and Benefits

Your newly purchased Crusader Water Quality Management System utilizes robust water treatment technologies that allow you to enjoy cleaner, softer, and better water.

## **Efficient**

The Crusader System learns your lifestyle and quickly adapts itself to meet your needs to deliver exceptional water quality while also saving you salt, water, and electricity. The highly sensitive digital flow-meter installed in your system allows it to learn how much water you use and when you use it so it can adjust reserves and salt consumption to match your water-usage lifestyle while minimizing bacterial growth.

## **Upgradeable**

Designed for the future, your Crusader System is capable of being modularly upgraded as new technologies are developed to accommodate for rapidly degrading water conditions. The onboard control center can be updated with the latest software updates & upgrades as they become available.

## **Reliable**

The Crusader Water Quality Management System is built around open-platform technology that has a 40-year legacy of reliable design. It utilizes 21st century composite materials to ensure reliable and dependable performance.

## **Safe**

Every Crusader System is handcrafted in the USA by skilled artisans in a world-class facility to provide you with a water treatment system that exceeds industry safety, manufacturing, and quality control standards to ultimately give you peace of mind.

## **Simple**

Advanced manufacturing methods and skillfully crafted computer hardware & software make a Crusader Water Quality Management System one of the easiest water quality improvement systems to own and operate.

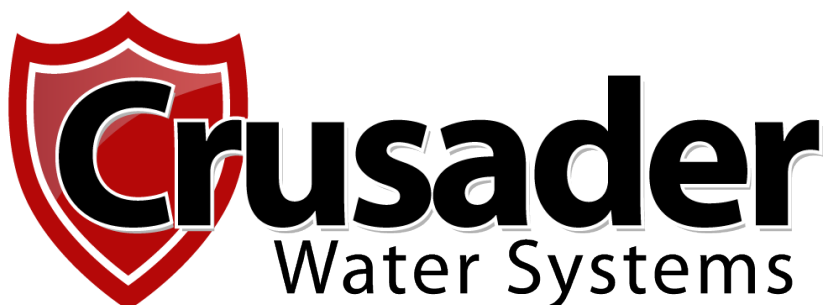

# System Components (Pro Model)

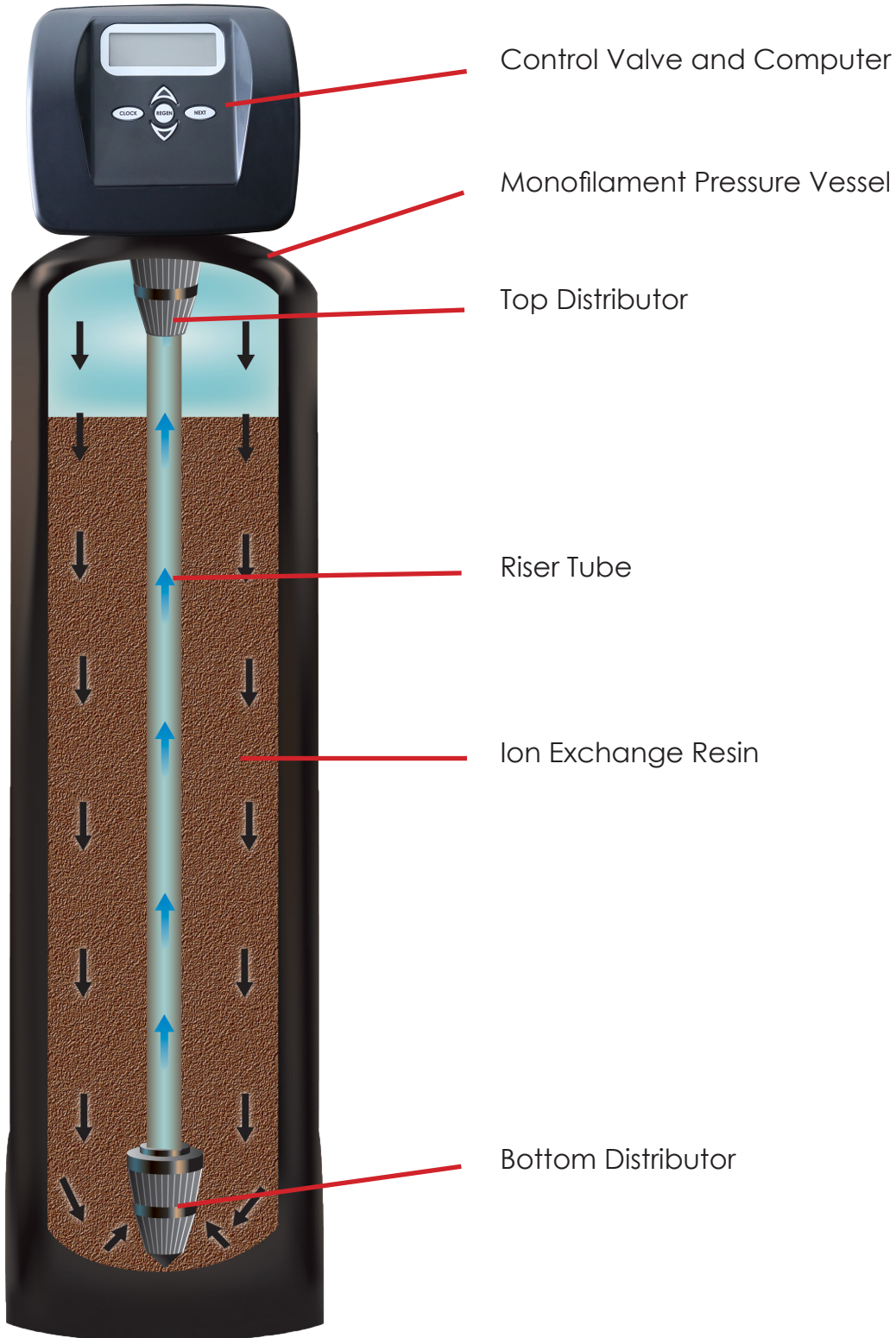

	The system must be <b>BYPASSED, DEPRESSURIZED, and DE-ENERGIZED</b> before assembling or performing mechanical repairs		Disassembly, Repair, Replacement, and/or Reassembly should only be performed by properly trained service personnel
--	--	--	--

# System Components (Deluxe Model)

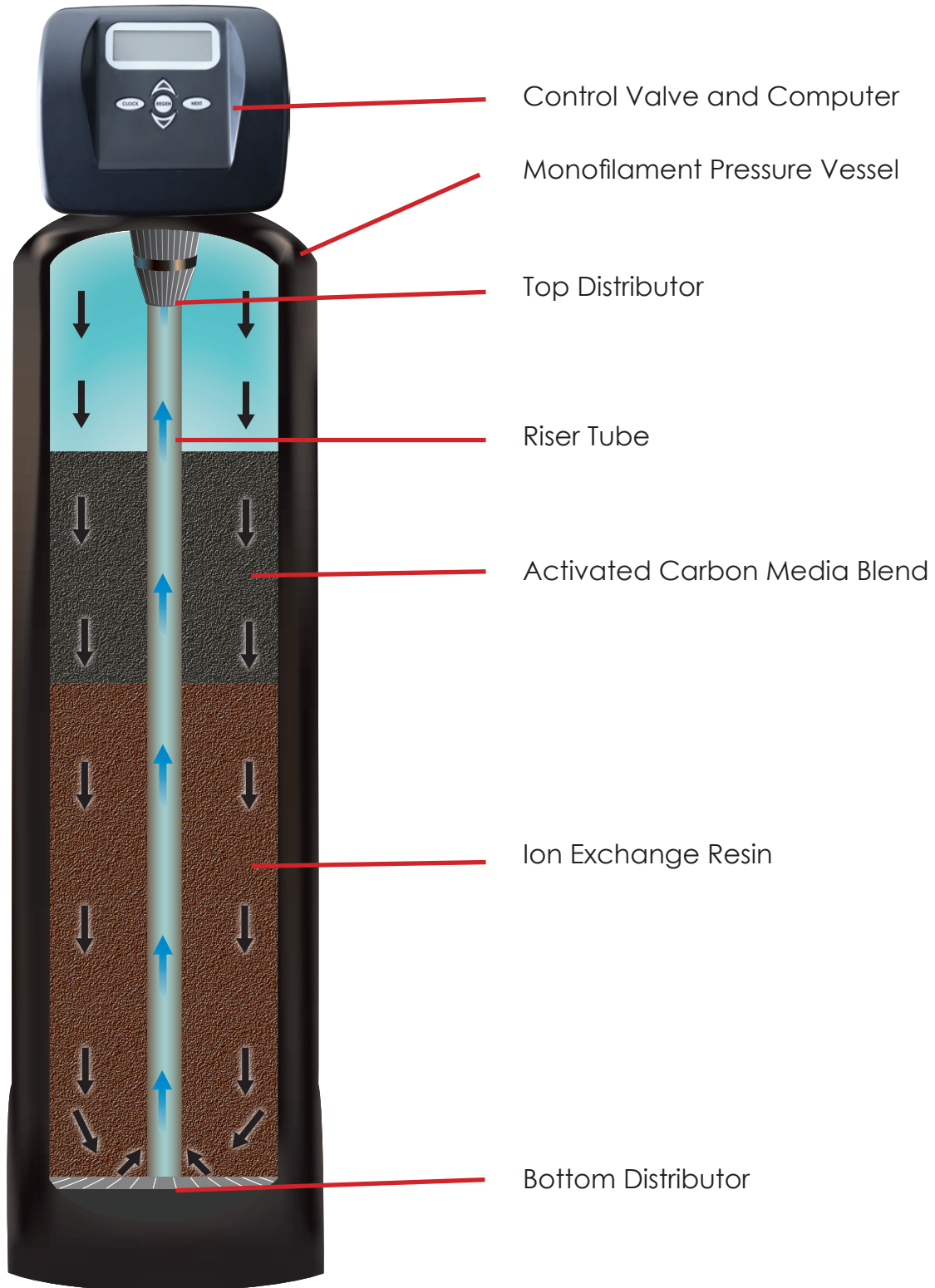

The system must be **BYPASSED, DEPRESSURIZED, and DE-ENERGIZED** before assembling or performing mechanical repairs



Disassembly, Repair, Replacement, and/or Reassembly should only be performed by properly trained service personnel

# System Components (Enhanced Model)

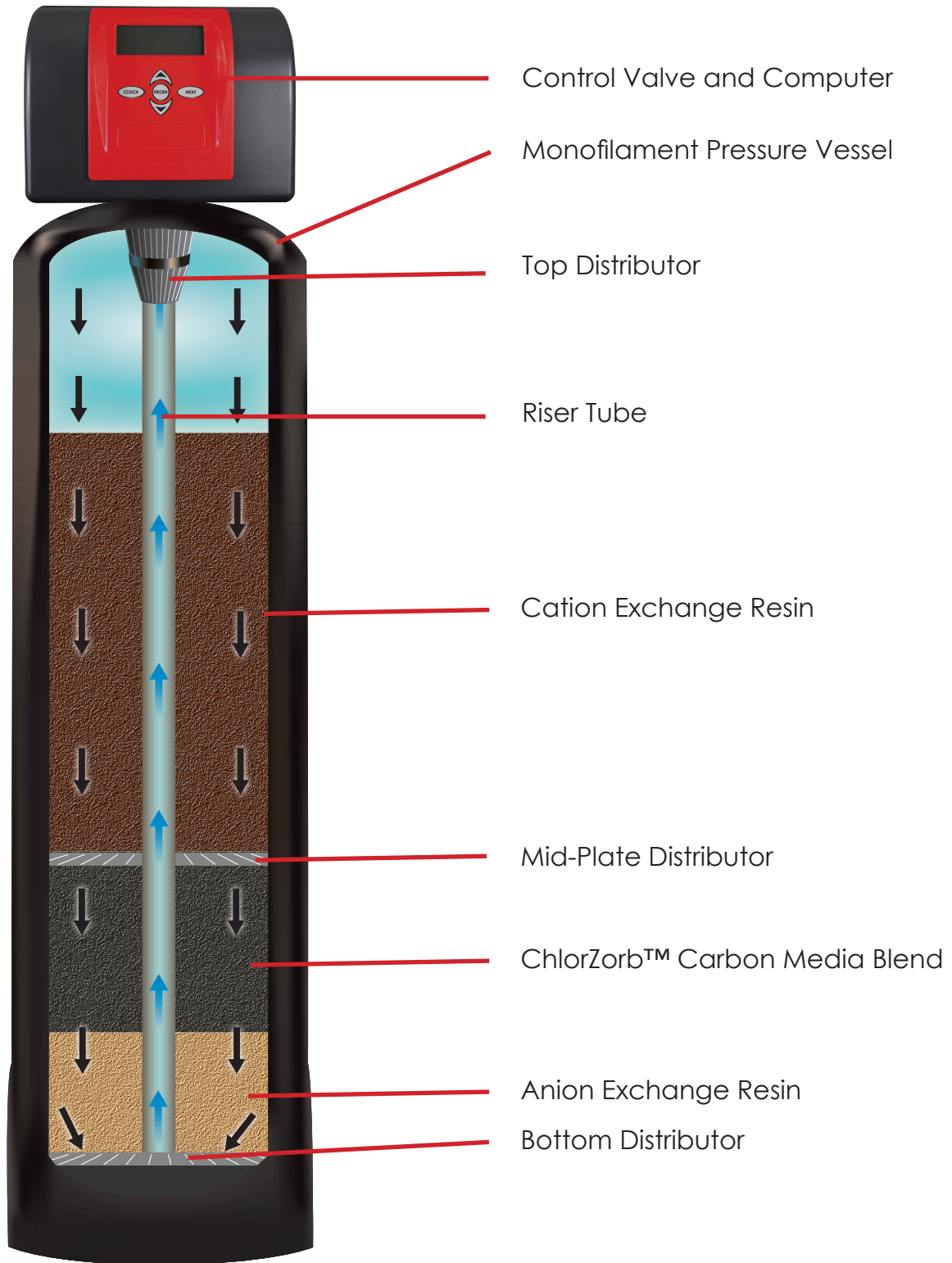

The system must be **BYPASSED, DEPRESSURIZED, and DE-ENERGIZED** before assembling or performing mechanical repairs



Disassembly, Repair, Replacement, and/or Reassembly should only be performed by properly trained service personnel

---

# Your Responsibilities as an Equipment Owner

Your Crusader Water Quality Management System is manufactured to be efficient and reliable. To ensure continued performance and to keep your system operating within manufacturer's specifications, the following operating conditions must be ensured by you, the equipment owner/operator:

## **Water Pressure Regulator**

The influent water pressure into this water system must be regulated by a code-compliant pressure-regulating device not to exceed 75 psi.

## **Power Protection**

Power to this system must be supplied by an unswitched 110VAC supply. Surge protection is mandatory and is to be supplied by you, the equipment owner. The use of a UPS (Uninterruptible Power Supply) is encouraged.

## **Salt**

This water system uses either sodium or potassium salt to clean itself. The brine tank must be filled with a high quality salt to ensure proper system operation. Consult with your local water professional to decide on the best salt for your area.

## **ProGuard**

The ProGuard reservoir should be kept full to ensure proper system operation and maximum efficiency. ProGuard works synergistically with the softening media to ensure the very best water feel and to maximize cleaning power. Check the level of your ProGuard feeder each time you fill your brine tank with salt.

## **Periodic Replacement of Media**

While built to the highest standards, certain media in your Crusader Water Quality Management System will need to be replaced periodically. Replacement intervals vary depending on your water chemistry and water consumption habits. Consult with your local water specialist to ensure that you always enjoy the very best water quality.

## **Periodic Water Testing**

Water quality fluctuates over time. We highly recommend testing your water every year to ensure you're getting the most out of your water. Your Crusader Water Professional may need you to test more frequently.

---

# ProGuard™

The ProGuard™ feeder incorporated into every Crusader Softening System ensures that you have the best water quality all year long. This simple dispensing system is specially engineered to work in all climates to easily introduce ProGuard into your brine tank while the system is waiting to clean itself.

Your Crusader System will use varying amounts of ProGuard depending on your water consumption habits; it will always try to maximize efficiency and performance to provide you with the water quality that you deserve.

ProGuard is designed to:

- Clean ion-exchange resin without damaging structured matrix media
- Clean all moving parts & create a temporary protective coating
- Create an inhospitable environment for bacteria in the system
- Remove oils and other hydrocarbons from resin
- Clean Activated Carbon Media
- Enhance self-sanitization processes on compatible systems
- Remove scale buildup from the valve internals, especially when source water contains high sulfates and hardness levels

Always keep your ProGuard reservoir full to ensure proper system performance, longevity, & efficiency.



# Cleaning and Disinfection

Your Crusader Water Quality Management System is probably the hardest working appliance in your home. Over its service life, it will process millions of gallons of water to protect you from countless amounts of inorganic calcium, magnesium, lead, copper, zinc, iron, manganese, and other contaminants that could be in your water.

In addition to capturing inorganic contaminants, your softener also accumulates sediment, bacteria, algae, mold, and fungus that can enter the system through city water, salt, or even from the air. These additional contaminants slowly accumulate in your softener and can colonize it with a biofilm of Heterotrophic Plate Count (HPC) bacteria. These bacteria are usually benign, but they can create a food base and safe refuge for potentially harmful pathogens and seriously compromise the longevity and performance of your system. While weekly antibacterial rinses and supplementation with ProGuard help minimize bacterial growth, your system should also be cleaned and disinfected on a regular schedule to ensure that it is working to the best of its ability and to protect the safety of your family.

## Recommended Cleaning & Disinfection Schedule

This chart shows the generally recommended monthly cleaning interval.\*\*

		# PEOPLE IN HOME					
		1	2	3	4	5	6
WATER HARDNESS (grains per gallon)	1	12	12	12	12	12	12
	5	12	12	12	12	12	12
	10	12	12	12	12	12	12
	15	12	12	12	12	12	12
	20	12	12	12	12	12	6
	25	12	12	12	6	6	6
	30	12	12	6	6	6	6
	40	12	12	6	6	6	6

Your local dealer can perform the cleaning and disinfection service for you, or you can purchase a comprehensive cleaning and disinfection kit to perform this task yourself.

\*\*The above recommended cleaning interval can vary depending on the quality of the water going into the system. It is strongly recommended to perform a water test and consult with your local authorized Crusader dealer to obtain an accurate recommended cleaning interval.



The system must be BYPASSED, DEPRESSURIZED, and DE-ENERGIZED before assembling or performing mechanical repairs



Disassembly, Repair, Replacement, and/or Reassembly should only be performed by properly trained service personnel

---

# System Control & Operation

Your Crusader Water Quality Management system incorporates a highly sophisticated microprocessor control system, which makes it as efficient and reliable as possible. All system settings are pre-programmed at the factory and then carefully calibrated by your qualified installer for your specific application and area.

Your Crusader Water Quality Management System incorporates flash EEPROM memory and an innovative power backup system, which means that your system programming should never have to be reset, even in the event of an extended power outage. Your system can also be upgraded with the latest software and hardware revisions as they become available. Contact your local authorized dealer for more information.

## **Normal Operating Mode**

In **Normal Operating Mode**, the display shows the time of day, capacity remaining, and the system status. Your system continuously monitors the flow meter and makes decisions on when and how to clean itself based on its programming profile and observations of your water-usage habits.

## **Flow Meter**

In **Service Mode**, the display will show the time of day and remaining capacity. The remaining capacity counts backwards in gallons as water is used. The flow display indicator can be used to determine if the flow meter is working by opening a faucet downstream of the system and observing the gallons countdown as well as the flow glyph.

## **Power-Failure Handling**

In the event of a power failure, your system's integrated snapshot memory system will retain all programmed data indefinitely. The system will maintain the correct time of day during a period of several hours. In the case of a prolonged power failure, the time of day might not be maintained; if this happens, the time of day indicator will be flashing when the power supply is reestablished. This flashing indicator lets you know that the time of day needs to be reset, and the CR2032 coin battery under the control valve cover should be replaced. All other programming is unaffected.

## **Critical Software/Hardware Failure**

After a critical software or hardware failure, an error code (see page 47 for error codes) will display on the screen and the system will not automatically cycle. Call your local service provider for help.

---

# System Control & Operation

## Cleaning/Regeneration Mode

Cycle times will vary depending on your water-usage habits, the system operational history, pre-programmed settings, and other environmental factors. In **Regeneration Mode** the display shows the current cleaning cycle description and the remaining time for that cycle to execute. The cleaning sequence is as follows:

<b>Tank Fill</b>	Your system calculates the exact amount of brine solution required to properly clean itself based on pre-programmed settings, operational history, your water-usage habits, and the age of the system. Your system is online and in service at this time.
<b>Percolation</b>	Your system remains online and in service while the water and salt slowly mix together to create a perfectly saturated sodium or potassium brine solution.
<b>Brine Draw</b>	Your system bypasses itself internally to prevent any salt or cleaning agents from entering your house's plumbing. Your system will then extract brine water from the brine tank and apply it to the ion-exchange media in the tank. This begins the ion-exchange process where trapped hardness and other contaminants are forced off of the ion-exchange resin beads.
<b>Slow Rinse</b>	Once the extracted brine supply is exhausted, your system will begin slowly rinsing contaminants through the media bed and out of the tank to drain.
<b>Backwash</b>	Your system rapidly discharges water upwards through the media to the drain. This ensures that trapped sediment & broken media are flushed out of the tank to minimize pressure loss & channeling.
<b>Rapid Rinse</b>	A high velocity stream of water is directed downwards through the multimedia bed to compact each of the media layers, flush hard water from the tank, and prepare for returning itself to service.
<b>Return to Service</b>	The system slowly drives the operating piston to the home position and gracefully brings itself back online, ready to work hard for you.

Your system will periodically perform a time-based antibacterial deep cleaning. This cleaning cycle will occur after a designated period of time (we recommend at least once a week). This cleaning cycle will inject ProGuard into your system and possibly even use salt to clean itself, depending on your water usage. If you haven't used any water during that interval, the system will not use any salt during the antibacterial cleaning cycle.

---

# Understanding How Your System Operates

Every day, approximately one trillion tons of water evaporate from the earth's surface. As the heat of the sun evaporates the water and draws it from the earth's surface into the atmosphere, many impurities are left behind. The water vapor eventually cools to form clouds and then falls back to earth as precipitation.

On its way from the clouds to your faucet, soft rain water dissolves and absorbs a part of almost everything it touches.

Falling rain cleans the air as it falls. Unfortunately, the impurities that were removed from the air have not left; they have just been relocated through the water onto the ground. These gases and other airborne contaminants can cause undesirable tastes, colors, and odors in water.

Rain falls onto the ground, collecting sediments like rust, sand, and even algae. The water eventually finds its way to a surface water supply or percolates downward and collects in an aquifer. As it percolates through the earth, the water can absorb hardness minerals, iron, heavy metals, radioactivity, organic contaminants, and many other complex elements and compounds.

Water can also collect numerous harmful man-made chemical impurities during this cycle. These synthetic chemicals are generally odorless, colorless, and tasteless; and can sometimes be life-threatening. The statement "my parents drank this water for 50 years and it never hurt them", is no longer a valid excuse to not be concerned with water quality. There has been a massive global increase in exposure to chemical waste over the last 50 years.

The scientific and medical community has not had adequate time or budget to study the long-term health effects of the more than 70,000 harmful chemicals that can be found in use today.

Approximately 1,000 new synthetic chemical compounds are entering the industrial marketplace each and every year. Precipitation falls upon commercial and municipal dump sites, toxic waste sites, industrial refuse depots, military test sites, leach fields, mining operations, farmer's fields, etc., where it dissolves minute amounts of the toxic chemicals present and carries them along into water sources.

In 1986, the United States Government estimated that close to two percent of the nation's ground water supplies were moderately polluted by sources such as hazardous waste dumps and leaking landfills.

Industrial wastewater is also a major source of water contamination. Chemicals that are considered generally acceptable in controlled amounts may react with other elements and/or chemicals to form new compounds that could be highly carcinogenic. Chlorine is one of the best-publicized examples. It reacts with organic matter in water and forms deadly trihalomethanes.

---

# Understanding How Your System Operates

Hard water is one of the major threats facing the American home in the 21st century. Hard water can coat you, your family, your home, and your appliances with thousands of pounds of inorganic mineral rock-scale each and every year. Hard water slowly destroys everything it touches. If left untreated, hard water costs you money, ruins your lifestyle, and can even lower the value of your home.

No one needs to tell you that you're living with hard water though. Soap doesn't lather easily, glasses are cloudy after washing, a ring forms around the bathtub, faucets and shower heads are crusty, laundering results are poor, and there are many other easily recognizable signs.

There are several degrees of water hardness. Even moderately hard water can seriously damage the plumbing system in your home and, in time, cause inconvenient and expensive problems.

Hard water is a poor cleaner because it is loaded with a variety of impurities. These dissolved impurities react with certain chemicals in soap and form a gummy, insoluble curd that clings stubbornly to everything it touches. The ring around your bathtub is curd. That same curd causes your hair to become dull, tangled, and hard to manage.

Soap curd clogs skin pores and prevents your natural oils from properly moisturizing your skin. This dryness causes itching and can also aggravate skin conditions like psoriasis, eczema, and acne.

Soap curd is especially noticeable by the scummy film it forms on dishes, glassware, appliances, walls, and floors. Hardness and other dissolved solids combine to form the residue you see as spots on glasses, crockery, cutlery, and shower enclosures.

## **How Water Hardness is Measured**

Water hardness is measured in imperial Grains per Gallon (gpg). A grain is the weight of an average dry grain of wheat, approximately 1/7000th of a pound.

<b>Soft Water</b>	0 - 0.5 gpg
<b>Slightly Hard Water</b>	0.5 - 3.5 gpg
<b>Moderately Hard Water</b>	3.5 - 7.0 gpg
<b>Very Hard Water</b>	7.0 - 10.5 gpg
<b>Extremely Hard Water</b>	10.5 gpg and greater

# Water Softening Process

Molecules are the smallest units of chemical compounds that still retain the compounds' properties. They consist of atoms or groups of atoms. When an atom carries an electrical charge, it is called an ion; an ion may be either positively or negatively charged. Metal and mineral ions are typically positively charged and are known as cations.

Ions such as chloride, fluoride, nitrate, phosphate, and sulfate are negatively charged and are known as anions.

Some insoluble materials consist of large ions arranged in a rigid, skeletal framework that contains oppositely charged ions. In an ion-exchange process, these ions can be swapped for other, similar ions.

Ion exchange was first applied commercially to water softening in 1905. Since then, it has proven to be one of the most reliable and cost-effective methods for softening and conditioning water in both residential and industrial settings.

Water softening by ion exchange works by replacing calcium and magnesium ions in the water with an equivalent number of sodium ions.

The softening process may be illustrated by the following equation:

<b>R2.Na +</b>	<b>Ca(HCO3)2 =</b>	<b>R2.Ca+</b>	<b>2NaHCO3</b>
Sodium Ion Exchange Resin	Calcium Bicarbonate in Water	Calcium Ion Exchange Resin	Sodium Bicarbonate in Water

The system can exchange only a limited amount of hardness and other contaminants before it becomes depleted. This limit is known as the resin's capacity. Capacity is typically expressed as the number of grains of calcium carbonate hardness removed per cubic foot of resin, or in milliequivalents per liter. Once the resin's capacity is used up, it must be regenerated using a sodium chloride (brine) solution, as described below:

<b>R2.Ca +</b>	<b>2NaCl =</b>	<b>2 R.Na +</b>	<b>CaCl2</b>
Calcium Ion Exchange Resin	Sodium Chloride Brine	Sodium Ion Exchange Resin	Calcium Chloride Water

Ion exchange resins used in your Crusader Water Quality Management System are made without harmful toxic solvents. This media is designed to be physically and chemically strong while producing water that feels good, tastes great, and works hard for you.

i	<p><b>Your Crusader Water Quality Management System can be regenerated with Potassium Chloride salt if desired.</b></p>
---	---

# Warnings & System Operational Requirements

The Crusader Water Quality Management System incorporates cutting-edge technology to bring you water that is perfectly soft and free of inorganic minerals.

Your system is designed to address certain impurities in your water through the process of salt-based ion exchange.

Your system should only be installed on water that is microbiologically safe. To ensure best performance, and maintain warranty compliance, the following installation requirements should be met:

	Minimum	Maximum
Water Temperature	30 °F	75 °F
Water Pressure	30 psi	75 psi
Influent Water Hardness	0 gpg	100 gpg*
Influent pH	6.7	8.7
Influent TDS	10 ppm	1,000 ppm*
Pathogenic Bacteria	0 CFU	0 CFU
Chlorine	0 ppm	3 ppm
Chloramine	0 ppm	1 ppm
Ambient Temperature	40 °F	120 °F

\* Influent water hardness levels above 22gpg and TDS above 500ppm will negatively impact the taste of the water



**DO NOT use with water that is unsafe or of unknown quality.**

**Test water periodically to verify that the system is performing satisfactorily.**

**Discard small parts remaining after installation.**



**Read and follow the information in this manual to minimize the risk of electric shock or personal injury.**

**If you are unsure about the installation of your system, contact technical support, a professional plumber, or certified water specialist.**



**This system must be installed in compliance with applicable state and local codes, applicable law, and regulations.**



**To bypass the system, turn bypass knob on both sides of the valve to bypass position. When returning to service, put the inlet into service before the outlet.**

---

# System Installation & Startup Guidelines

1. Clear the installation area and carefully sweep the floor where the system will be installed.
2. Test incoming water pressure and make sure it is **30 - 75 psi static**. A code-compliant pressure regulator must be installed to protect the system on all municipal water installations.
3. Check to confirm that the water heater has adequate heat expansion protection.
4. Install the system, drain, and brine tank overflow according to the manufacturer's instructions and prevailing local code.
  - Vinyl tubing should **NOT** be used for the drain tubing. Vinyl tubing has a high likelihood of collapsing and preventing proper regeneration.
5. Bypass the system.
6. Run bathtub cold to purge piping of debris and chemical residue from installation.
  - a. This will take approximately 5 minutes at 3 gpm.
7. Leave bathtub running and slowly open the **inlet** valve to the system.
8. Slowly open the **outlet** valve from the system.
9. Observe flow of water from the bathtub. Water may become a dark brown/black color. This color is caused by the system disinfectant/preservative as well as dust from shipping and handling. Allow water to run until clear, and observe water for particles. If resin or other softening media particles are found in the water, bypass the system and call tech-support. Leave bathtub running.
10. Enter programming mode:
  - Program the system to match the installation configuration and operating conditions (see page 25 for system programming instructions).
  - Begin a cleaning cycle by pressing and holding the  button for at least 5 seconds.
  - Advance the system through each cycle step by pressing the  button.
  - Observe the system during each cycle and then progressively advance to the next until the regeneration terminates.
11. Once the system has been advanced to normal operating mode, observe the flow of water from the bathtub again for any sign of disinfectant or resin. Allow water to run clear. Turn bathtub off.

# Installation And Startup Checklist

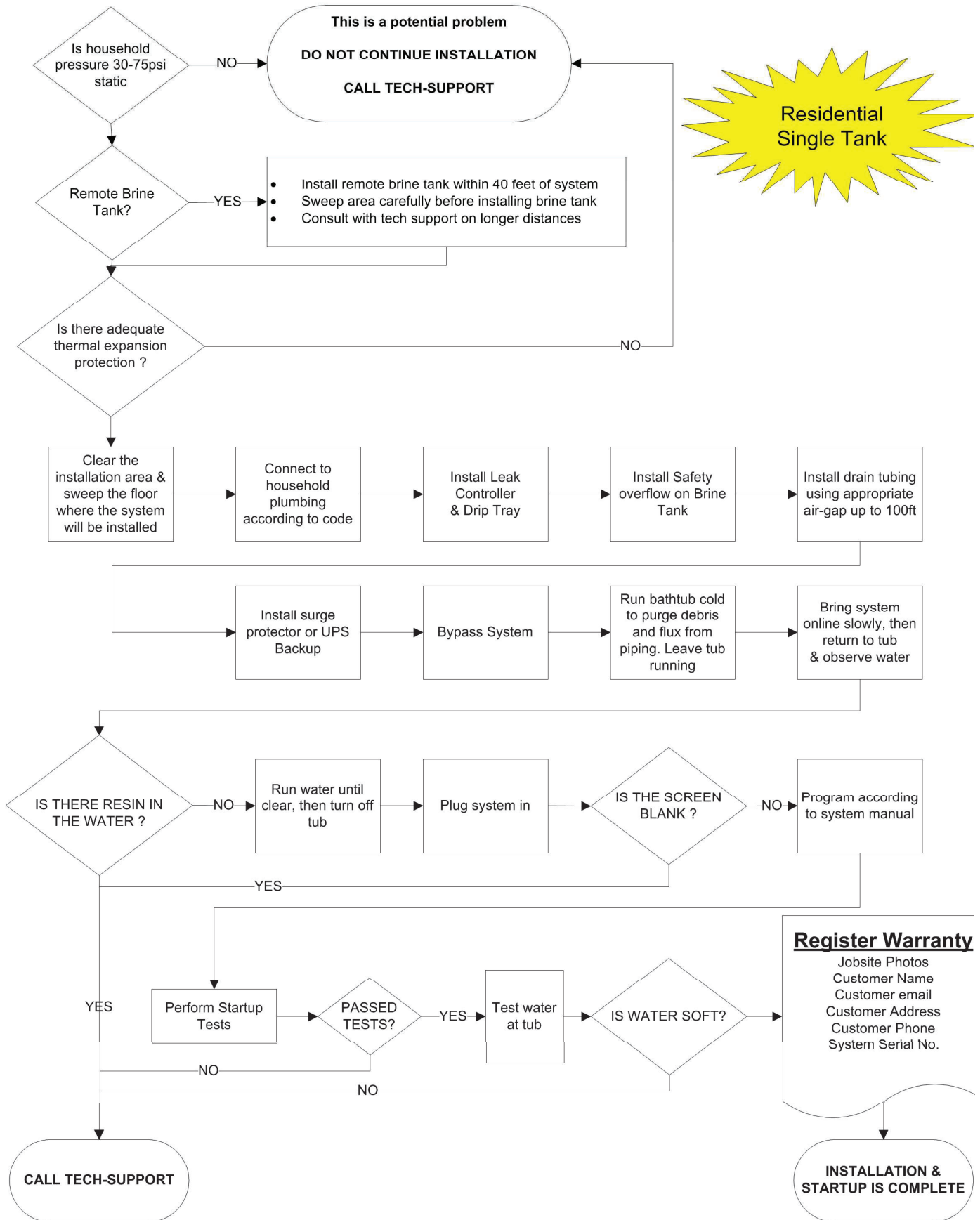

# Control Valve Operating Parameters

Minimum / Maximum Operating Pressures	30 psi (138 kPa) - 75 psi (862 kPa)
Minimum / Maximum Operating Temperatures	40 °F (4 °C) - 110 °F (43 °C)
Supply Voltage / Frequency	120V AC / 60 Hz (Other Options Available)
Power Consumption	9.5 W
Output Voltage	12VDC - 15VDC
Output Current	500 mA

## General Warnings



**THE CONTROL VALVE, FITTINGS, AND/OR BYPASS ARE DESIGNED TO ACCOMODATE MINOR PLUMBING MISALIGNMENTS BUT ARE NOT DESIGNED TO SUPPORT THE WEIGHT OF A SYSTEM OR THE PLUMBING.**



**HYDROCARBONS SUCH AS KEROSENE, BENZENE, GASOLINE, ETC. MAY DAMAGE PRODUCTS THAT CONTAIN O-RINGS OR PLASTIC COMPONENTS.**

**EXPOSURE TO SUCH HYDROCARBONS MAY CAUSE THE PRODUCTS TO LEAK. DO NOT USE THE PRODUCT(S) CONTAINED IN THIS DOCUMENT ON WATER SUPPLIES THAT CONTAIN HYDROCARBONS SUCH AS KEROSENE, BENZENE, GASOLINE, ETC.**





**THIS WATER METER SHOULD NOT BE USED AS THE PRIMARY MONITORING DEVICE FOR CRITICAL OR HEALTH EFFECT APPLICATIONS.**



**DO NOT USE VASELINE, OILS, OTHER HYDROCARBON LUBRICANTS, OR SPRAY SILICONE ANYWHERE. A SILICONE LUBRICANT MAY BE USED ON BLACK O-RINGS BUT IS NOT NECESSARY.**

- The nuts and caps are designed to be unscrewed or tightened by hand or with the special plastic wrench. If necessary, pliers can be used to unscrew the nut or cap. Do NOT use a pipe wrench to tighten or loosen nuts or caps. **DO NOT** place a screwdriver in the slots on caps and/or tap with a hammer.

# General Warnings Continued

- **DO NOT** use pipe dope or other sealants on threads. Use Teflon tape on the threaded inlet, outlet, and drain fittings. Teflon tape is not necessary on the nut connection or caps because of o-ring seals.
- After completing any valve maintenance involving the drive assembly or the drive cap assembly and pistons, unplug the power source jack from the printed circuit board (black wire) and plug back in or press and hold  and  buttons for 3 seconds. This resets the electronics and establishes the service piston position. The display should flash all wording, then flash the software version, and then reset the valve to the service position.
- All plumbing should be done in accordance with local plumbing codes. The pipe size for the drain line should be a minimum of 1/2". Backwash flow rates in excess of 7 gallons per minute or lengths in excess of 20 feet require a 3/4" drain line.
- Solder joints near the drain must be done prior to connecting the drain line flow control fitting. Leave at least 6" between the drain line control fitting and solder joints when soldering pipes that are connected on the drain line control fitting. Failure to do this could cause interior damage to the drain line flow control fitting.
- When assembling the installation fitting package (inlet and outlet), connect the fitting to the plumbing system first and then attach the nut, split ring, and o-ring. Heat from soldering or solvent cements may damage the nut, split ring, or o-ring. Avoid getting primer and solvent cement on any part of the o-rings, split rings, bypass valve, or control valve.
- Plug into an electrical outlet. Note: All electrical connections must be connected according to local codes. (Be certain the outlet is uninterrupted.)
- Install grounding strap on metal pipes.
- The control valve is capable of routing the flow of water in the necessary paths to regenerate or backwash water treatment systems. The injector regulates the flow of brine or other regenerants. The control valve regulates the flow rates for backwashing, rinsing, and the replenishing of treated water into a regenerant tank, when applicable.



**ProGuard™ is the best resin cleaner and disinfectant for your system.**



**IT IS NOT RECOMMENDED TO CHANGE CONTROL VALVES FROM DOWNFLOW TO UPFLOW BRINING OR VICE VERSA IN THE FIELD. THE VALVE BODIES FOR DOWNFLOW AND UPFLOW ARE UNIQUE TO THE REGENERATION TYPE AND SHOULD NOT BE INTERCHANGED. A MISMATCH OF THE VALVE BODY AND REGENERATION PISTON WILL RESULT IN HARD WATER BYPASS DURING SERVICE.**

---

# General Warnings Continued

- The control valve uses no traditional fasteners (e.g. screws); instead clips, threaded caps, and nuts and snap type latches are used. Caps and nuts only need to be firmly hand tightened because radial seals are used.
- Tools required to service the valve include one small flat blade screwdriver, one large flat blade screwdriver, and pliers. (A plastic wrench is available, which eliminates the need for screwdrivers and pliers.)
- Disassembly for servicing takes much less time than comparable products currently on the market. Control valve installation is made easy because the distributor tube can be cut 1/2" above or below the top of the tank thread.
- The distributor tube is held in place by an o-ring seal and the control valve also has a bayonet lock feature for upper distributor baskets.
- The AC adapter comes with a 15-foot power cord and is designed for use with the control valve. The AC adapter is for dry location use only.
- The control valve remembers all settings until the battery power is depleted if the power goes out. After the battery power is depleted, time of day is the value that needs to be reset. All other values are permanently stored in the nonvolatile memory.
- The control valve battery (CR2023) is not rechargeable but is replaceable.

## Installation Instructions

- The valve will withstand transportation and storage temperatures of -13 °F (-25 °C) to 131 °F (55 °C) and for short periods up to 158 °F (70 °C). If valve has been exposed to freezing conditions let valve warm up to room temperature before running water through it.
- Place softener in desired location close to water supply inlet, after pressure tank, and near a source for waste water, (utility sink, floor drain, or sewer line). Allow one foot of clearance to service the valve.
- A 115/120V, 60 Hz uninterrupted outlet is required.
- All sillcocks and similar fixtures that will use untreated water must have their pipes connected to the hard water side of the softener. The bypass valve should be installed so that water will be available if it should be necessary to shut off the pressure in order to service the softener.
- The cabinet tank or mineral tank must be reasonably level and solidly in place. Prior to beginning work to the system, make sure that water pressure is shut off at the incoming water supply and that several water spigots are open to provide sufficient venting for drainage of that system.
- Arrows are molded into the control valve to show the direction of the flow.

# Installation Instructions Continued

- **BYPASS VALVE:** The bypass valve easily connects to the control valve body using nuts that only require hand tightening. Install with red knobs in the **upward** position. Press end of bypass valve with o-rings into valve. Hand tighten nuts. Place into **BYPASS OPERATION** (Page 23, Figure 1).
- Avoid getting primer and solvent cement on any part of the o-rings or split rings, bypass valve or control valve. **DO NOT** use pipe dope or any other sealant on threads. Teflon tape is not necessary on the caps because of o-ring seals. Do not use Vaseline or other unacceptable lubricants on o-rings. A silicone lubricant may be used on black o-rings.

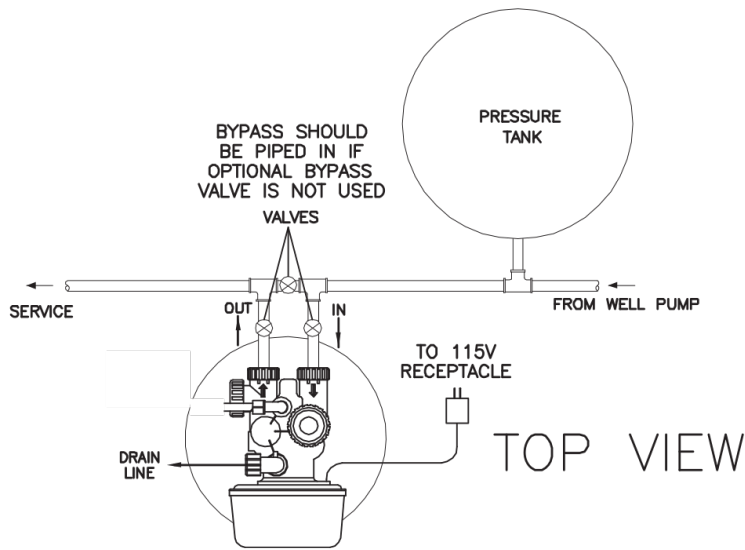

## BYPASS OPERATION

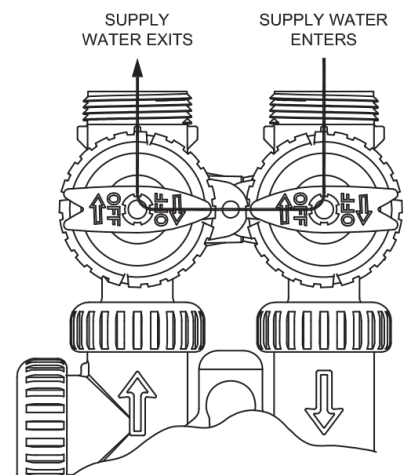

## DIAGNOSTIC MODE

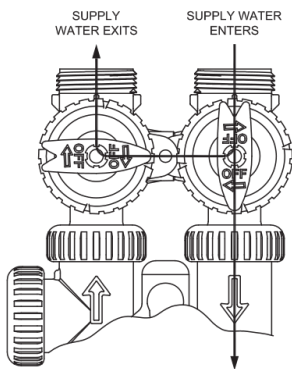

## NORMAL OPERATION

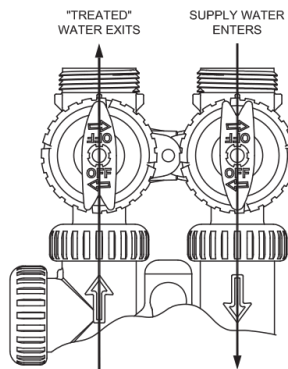

## SHUT OFF MODE

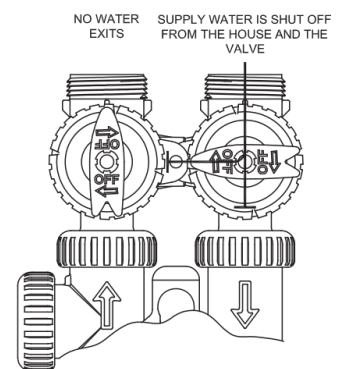

---

# Installation Instructions Continued

- **DRAIN LINE:** The 3/4" drain line elbow accommodates 5/8" polytube or 3/4" NPT drain line connections. The nut and polytube insert for the 3/4" drain line elbow is designed for use with flexible polytube **only**. The drain line elbow can be rotated so the outlet can be oriented toward the nearest drain.
- **TO INSTALL 5/8" POLYTUBE DRAIN LINE:** The polytube insert is shipped attached to the drain line elbow's locking clip. Press the insert into the drain line (5/8" polytube not included). Loosen nut of the drain line elbow. Press 5/8" polytube with insert into the drain line elbow until it seats on the back of the fitting. Tighten nut. It is simplest to run the drain line into a sump pump pit or washing machine drain if possible. If this is not practical, a fitting with a trap must be installed in a sewer line. Place the trap as close to the vent as possible to prevent siphoning of the trap when large amounts of wastewater go through the sewer line. **DO NOT** pipe the drain line directly into the waste line, as this is prohibited by most plumbing codes. The drain line should enter the trap from above so the water will not back up in the drain line if sewer should become plugged up and the trap overflow. The trap should have a short pipe extending from it to prevent splashing when water runs into the trap from drain line.
- **ASSEMBLE THE BRINE TANK (Refer to Page 29):** Install a brine well cap (Item A) on the bottom of the brine well (Item B). Remove the brine valve assembly (Item C) from the brine well by removing the nut (Item D). Attach the brine well to the brine tank with the two-piece overflow (Items E & F) using the lower holes in both pieces, as shown. Reinstall the brine valve assembly. Push brine line polytube (Item G) through the upper holes in the brine tank and brine well and press the polytube into the elbow fitting.

## BRINE LINE FITTING CONNECTIONS

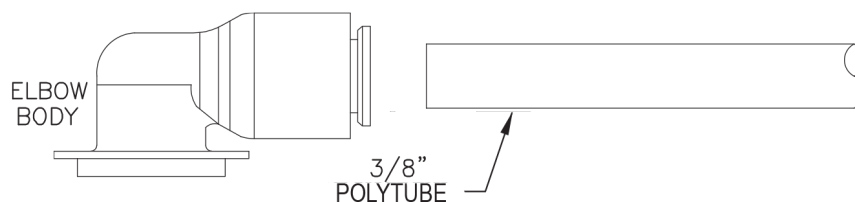

- **BRINE LINE CONNECTIONS:** Connect the brine line polytubing found with the brine tank to the brine connection on the control valve. The control valve has a standard refill elbow to which a 3/8" flexible tube can be connected, see below. Press the polytube into the brine elbow fitting. Make sure the floor is clean beneath the brine tank and that it is level and smooth.
- **BRINE TANK OVERFLOW PRECAUTION:** A 1/2" (inside diameter, not provided) gravity drain line should be connected to the overflow fitting on the side of the brine tank. This overflow is in case of a malfunction in the brine shut off. If the unit is installed where water may flow in the event of an overflow and cause water damage, connect a length of flexible tubing and run to a drain below the level of the overflow. (**DO NOT** connect the tubing to the drain line on the control valve. **DO NOT** run tubing above overflow height at any point.)

# System Programming

## Set Time Of Day

Current time of day needs to be entered during initial installation, and adjusted when daylight saving time begins or ends. If an extended power outage occurs and depletes the on-board non-rechargeable coin cell battery, replace the battery when power resumes and reset the time of day.

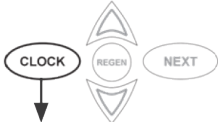

### STEP 1



**STEP 1:** Press **CLOCK**

### STEP 2





**STEP 2:** Current Time (hour): Set the hour of the day using  or  buttons. AM/PM toggles after 12. Press **NEXT** to go to Step 3.



### STEP 3



**STEP 3:** Current Time (minutes): Set the minute of the day using  or  buttons. Press **NEXT** to Set time of Day. Press **REGEN** to return to previous step.



RETURN TO NORMAL MODE

# System Programming

## Adjust Hardness, Days Between Regenerations, Time of Regeneration, & Backlight Operation

### STEP 1

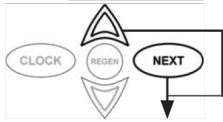

### STEP 2



### STEP 3

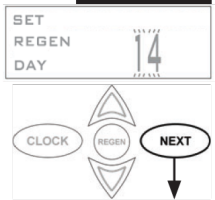

### STEP 4



### STEP 5



### STEP 6

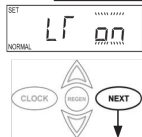

RETURN TO NORMAL MODE

**STEP 1:** Press **NEXT** and **Up arrow** simultaneously for 3 seconds to access Installer Display Settings.

**STEP 2 - Hardness:** Set the amount of hardness in grains of hardness as calcium carbonate per gallon using the **Up arrow** or **Down arrow** buttons. To accommodate for fluctuations in water quality, this value should be set at 10% above the tested hardness in GPG. The default is 20 with value ranges from 1 to 150 in 1 grain increments. **Note: the grains per gallon can be increased if soluble iron needs to be reduced.**

Press **NEXT** to go to step 3. Press **REGEN** to exit Installer Display Settings.

**STEP 3 - Day Override:** Set the maximum number of days between regenerations. **Note: 7 days between regeneration is recommended as an anti-bacterial measure.** If value is set to "OFF", regeneration initiation is based solely on volume used. If value is set as a number (allowable range from 1 to 28), a regeneration initiation will be called for on that day even if sufficient volumes of water were not used to call for a regeneration. Set day override using **Up arrow** or **Down arrow** buttons: - number of days between regeneration (1 to 28) or -"OFF"

Press **NEXT** to go to step 4. Press **REGEN** to return to previous step.

**STEP 4 - Next Regeneration Time (hour):** Set the hour of the day for regeneration using **Up arrow** or **Down arrow** buttons. AM/PM toggles after 12. The default time is 2:00 AM. Press **NEXT** to go to Step 5. Press **REGEN** to go to previous step.



**STEP 5 - Next Regeneration Time (minutes):** Set the minutes of the day for regeneration using **Up arrow** or **Down arrow** buttons. AM/PM toggles after 12. The default time is 2:00 AM. Press **NEXT** to go to Step 6. Press **REGEN** to go to previous step.

**STEP 6 - Set Backlight Operation (available on some models):** Set the Backlight Operation using **Up arrow** or **Down arrow** buttons. "ON" Indicates the backlight is always on. "OFF" sets the backlight to go off after 5 minutes of inactivity. Press **NEXT** to return to normal operation. Press **REGEN** to return to the previous step.

---

# Placing Unit Into Service

Ensure inlet and outlet valves are in their closed positions. If using optional bypass, place in bypass position. Turn on main water supply. Open a cold water faucet. This will clear the lines of any debris (solder, pipe dope, etc.) that may be in the line. Let water run at tap for a couple of minutes, or until clear. Turn off faucet.

- Press and hold the  button for approximately 5 seconds until the motor starts.
- Wait until display reads **BACKWASH** and numbers start counting down.
- Momentarily press  again. Wait until display reads **BRINE** and numbers start counting down.
- Momentarily press  again. Valve is now in the second **BACKWASH** position.

If using optional bypass, SLOWLY turn bypass valve to **DIAGNOSTIC** position (Page 23, Figure 2) or slowly open inlet valve to allow water to slowly enter the softener.

When water is flowing steadily to drain without the presence of air, momentarily press  again. Display will read "**RINSE**".

Open the outlet valve of the softener, or if using optional bypass place to **NORMAL OPERATION MODE** (Page 23, Figure 3).

Allow control to finish the **RINSE** cycle. The system will advance to the **FILL** position. The brine tank will now automatically fill with the proper volume of water for the first regeneration.

Allow the control to automatically advance to the **SOFTENING** position. Load the brine tank with salt. Solar Salt is recommended.

# Parts Diagrams

## ProGuard Feeder

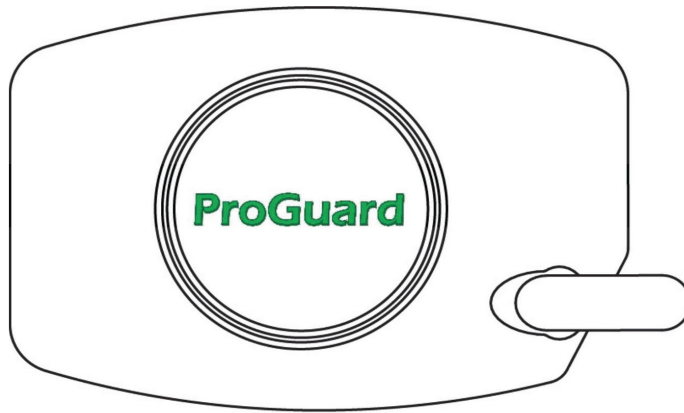

Item No.	Qty.	Part No.	Description
1	1	PGF01	ProGuard Feeder



**Do not fill the ProGuard Feeder above the 'Maximum' line on the label. Overfilling may result in premature siphoning, emptying the feeder prematurely.**



**Disassembly, Repair, Replacement, and/or Reassembly should only be performed by properly trained service personnel.**

# Parts Diagrams

## Brine Tank

A	Brine Well Cap
B	Brine Well
C	Safety Brine Valve Assembly (3/8" John Guest)
D	474 Series Float and Brine Draw Tube Assembly
E	Brine Overflow Elbow Nut
F	Brine Overflow Elbow
G	3/8" John Guest Tubing (18" Length Included with Systems)

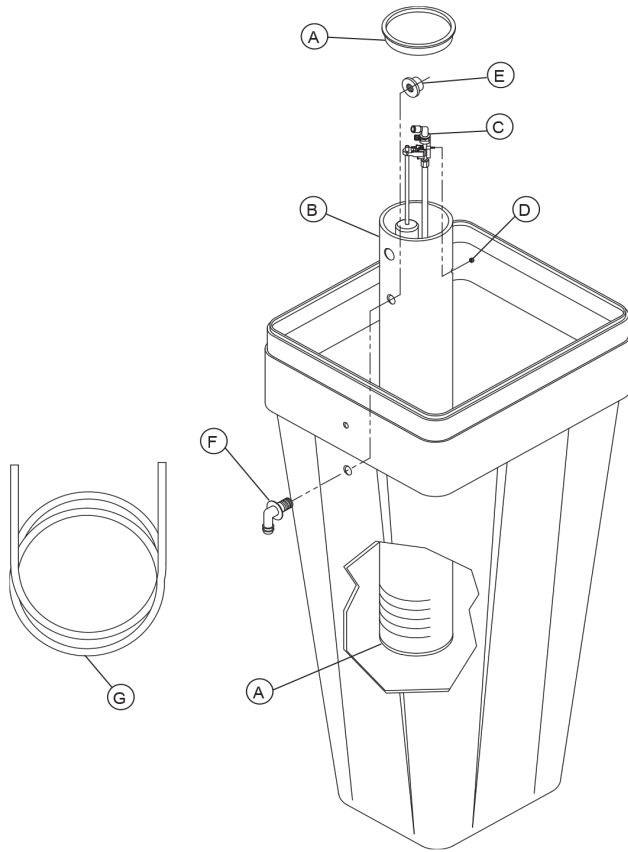

**ProGuard**

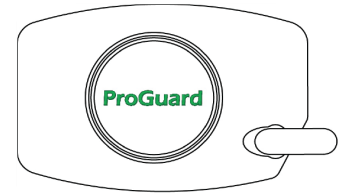

## Optional Maintenance Wrench

Part Number V3193

The optional maintenance wrench (shown in various positions on the valve) may be purchased to aid in assembly or disassembly.

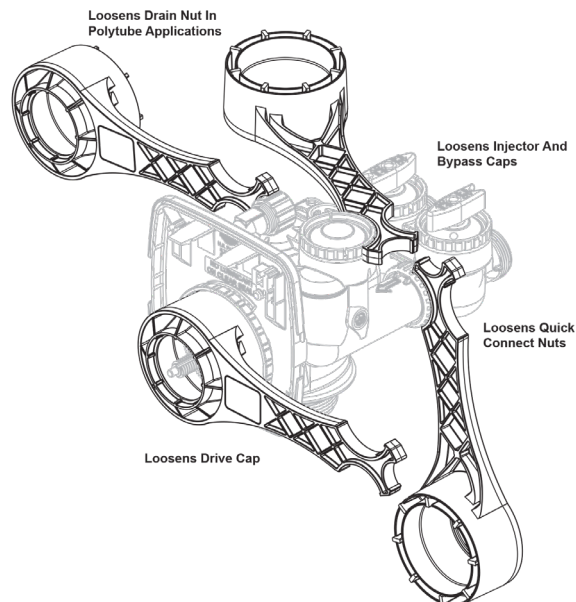

# Parts Diagrams

## Front Cover And Drive Assembly

Drawing No.	Order No.	Description	Quantity
1	V3692-01RN	Front Cover Assembly	1
2	V3107-01	Motor	1
3	V3106-01	Drive Bracket & Spring Clip	1
4	V3757PR-03	PC Board	1
5	V3110	Drive Gear 12x36	3
6	V3109	Drive Gear Cover	1

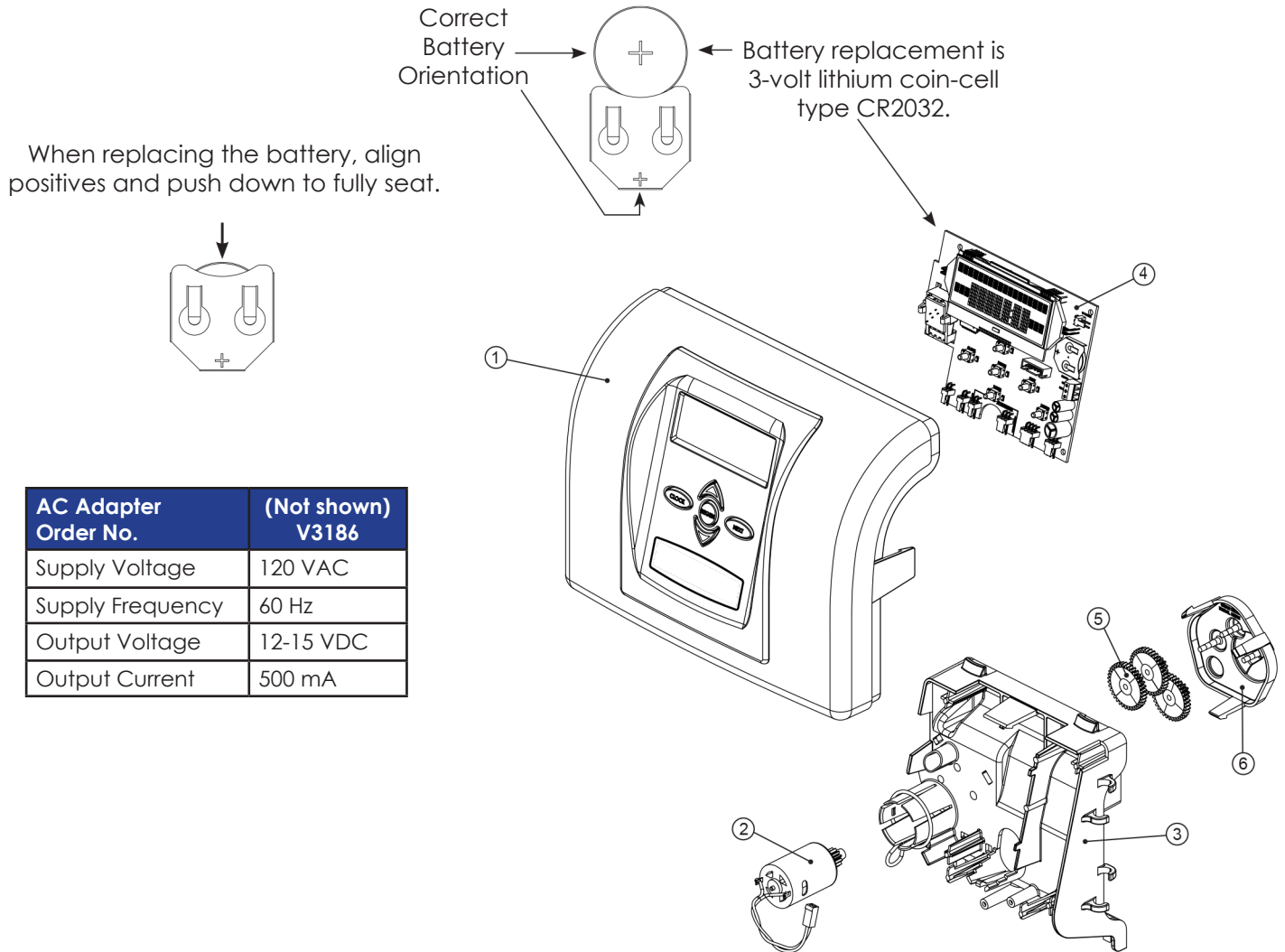

AC Adapter Order No.	(Not shown) V3186
Supply Voltage	120 VAC
Supply Frequency	60 Hz
Output Voltage	12-15 VDC
Output Current	500 mA

After completing **ANY** valve maintenance involving the drive assembly or the drive cap assembly and pistons:

- 1) Unplug power source jack from the printed circuit board (black wire) for 30 seconds.
- 2) Plug back in, and press and hold **NEXT** and **REGEN** buttons for 3 seconds.

This resets the electronics and establishes the service piston position. The display should flash the software version and then reset the valve to the service position.



# Parts Diagrams

## Drive Cap, Upflow Piston, Regenerant Piston, And Spacer Stack Assembly

Item No.	Part No.	Description	Quantity
1	V3005	Spacer Stack Assembly	1
2	V3004	Drive Cap Assembly	1
3	V3135	O-Ring 228	1
4	V3011-01	Upflow Piston Assembly	1
5	V3174	Regenerant Piston	1
6	V3105	O-Ring 215	1
7	V3180	O-Ring 337	1
8	V3690	Back Plate	1

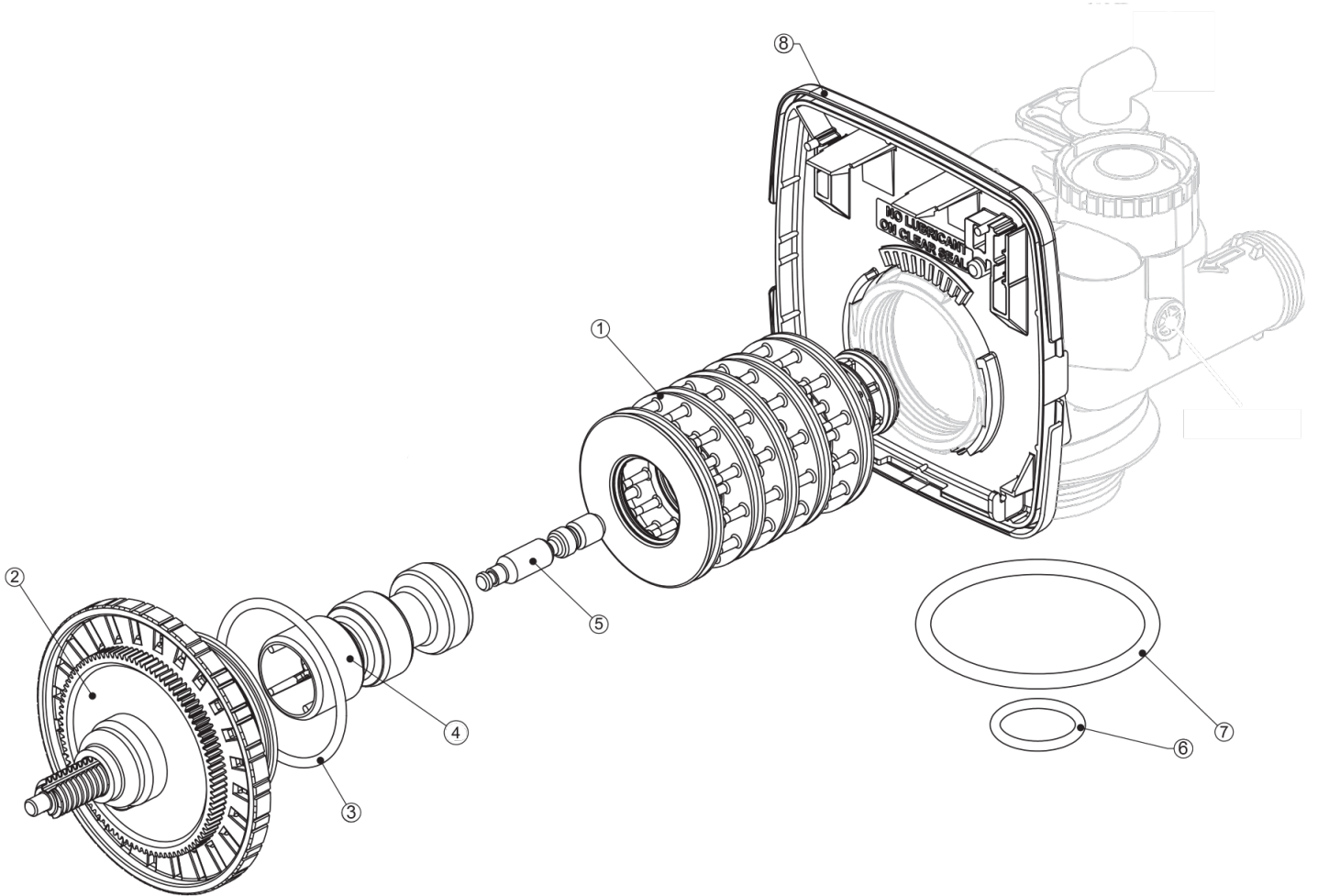

After completing **ANY** valve maintenance involving the drive assembly or the drive cap assembly and pistons:

- 1) Unplug power source jack from the printed circuit board (black wire) for 30 seconds.
- 2) Plug back in, and press and hold **NEXT** and **REGEN** buttons for 3 seconds.

This resets the electronics and establishes the service piston position. The display should flash the software version and then reset the valve to the service position.

# Parts Diagrams

## 1.25" Drive Assembly And Upflow Piston

Drawing No.	Order No.	Description	Qty
1	V3430	Spacer Stack Assembly	1
2	V3004	Drive Cap Assembly	1
3	V3690	Back Plate	1
4	V4042	Piston Upflow Assembly	1
5	V3174	Regenerant Piston	1
6	V3135	O-Ring 228	1
7	V3180	O-Ring 337	1
8	V3358	O-Ring 219 (Distributor Tube)	1

After completing any valve maintenance involving the drive assembly or the drive cap assembly and pistons, unplug power source jack from the printed circuit board (black wire) and plug back in or press and hold **NEXT** and **REGEN** buttons for 3 seconds. This resets the electronics and establishes the service piston position. The display should flash the software version and then reset the valve to the service position.

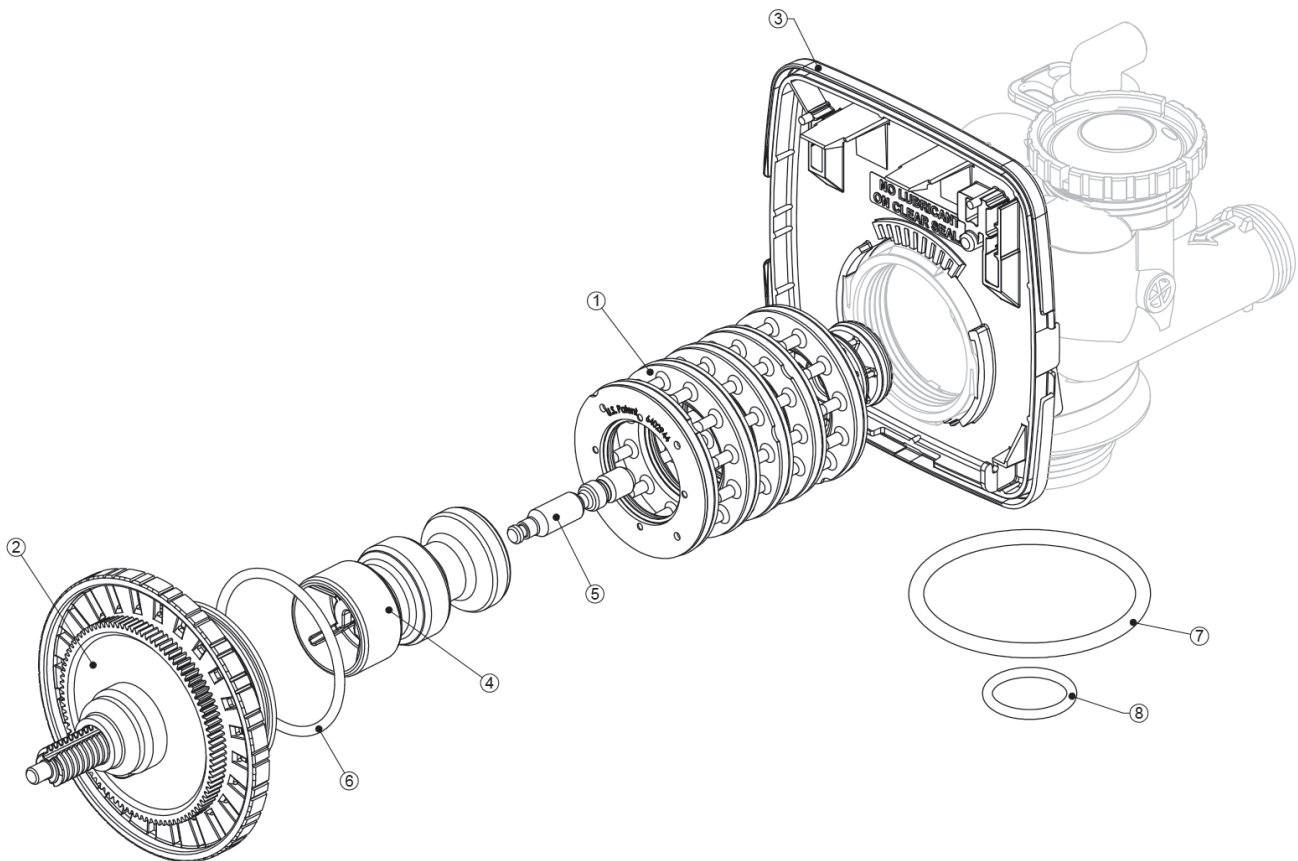

**Avoid any type of lubricants, including silicone, on the clear lip seals.**

Do not use Vaseline, oils, other hydrocarbon lubricants or spray silicone anywhere. A silicone lubricant may be used on black o-rings but is not necessary.

# Parts Diagrams

## Injector Cap, Screen, Plug, And O-Ring

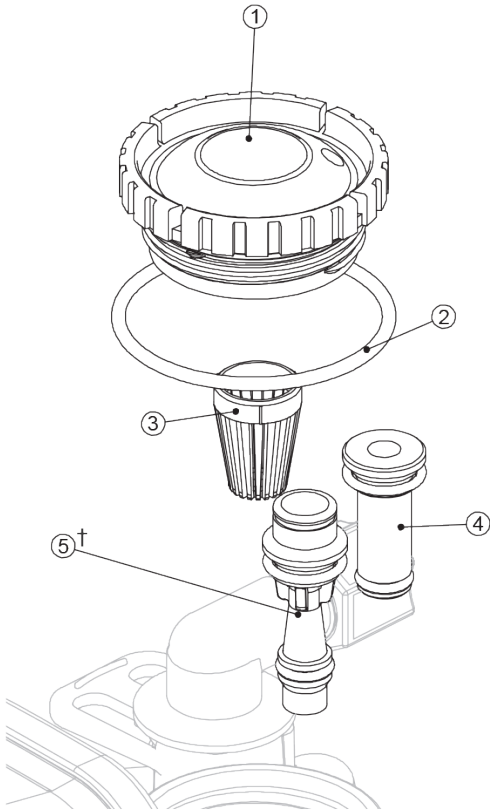

Drawing No.	Order No.	Description	Qty
1	V3176	Injector Cap	1
2	V3152	O-Ring 135	1
3	V3177-01	Injector Screen Cage	1
4	V3010-1Z	Injector Assembly Z Plug	1
5	V3010-1C	Injector Assembly C Violet	1
	V3010-1F	Injector Assembly F Blue	1
	V3010-1H	Injector Assembly H Green	1
Not Shown	V3170	O-Ring 011	*
Not Shown	V3171	O-Ring 013	*

\* The injector plug and the injector each contain one 011 (lower) and 013 (upper) o-ring.



**Do not use a pipe wrench to tighten or loosen nuts or caps. Do not place a screwdriver in slots on caps and/or tap with a hammer.**

The nut and caps are designed to be unscrewed or tightened by hand or with the service spanner wrench (V3193) (Page 29). If necessary, pliers can be used to unscrew the nut or cap.

# Parts Diagrams

## Water Meter

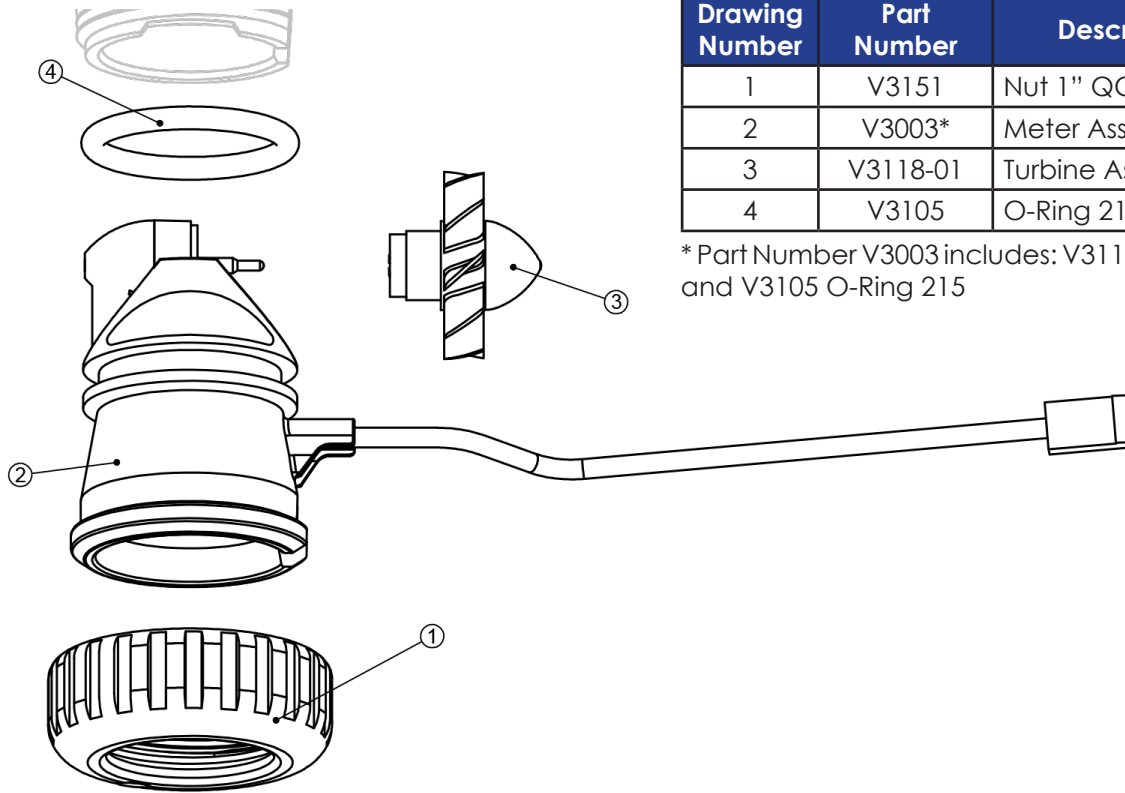

Drawing Number	Part Number	Description	Quantity
1	V3151	Nut 1" QC	1
2	V3003*	Meter Assembly	1
3	V3118-01	Turbine Assembly	1
4	V3105	O-Ring 215	1

\* Part Number V3003 includes: V3118-01 Turbine Assembly and V3105 O-Ring 215



**THIS WATER METER SHOULD NOT BE USED AS THE PRIMARY MONITORING DEVICE FOR CRITICAL OR HEALTH EFFECT APPLICATIONS.**

The nut and caps are designed to be unscrewed or tightened by hand or with the service spanner wrench (V3193) (Page 29). If necessary, pliers can be used to unscrew the nut or cap.

**DO NOT use a pipe wrench to tighten or loosen nuts or caps.**

**DO NOT place a screwdriver in slots on caps and/or tap with a hammer.**

# Parts Diagrams

## Drain Line - 3/4"

Drawing No.	Order No.	Description	Qty
1	H4615	Elbow Locking Clip	1
2	V3194	Polytube Insert 5/8"	Optional
3	V3192	Nut 3/4" Drain Elbow	Optional
4*	V3158	Drain Elbow 3/4" Male	1
5	V3163	O-Ring 019	1
6*	V3159	DLFC Retainer Assembly	1
7	V3162-007	DLFC 0.7 gpm for 3/4"	One DLFC must be used if 3/4" fitting is used
	V3162-010	DLFC 1.0 gpm for 3/4"	
	V3162-013	DLFC 1.3 gpm for 3/4"	
	V3162-017	DLFC 1.7 gpm for 3/4"	
	V3162-022	DLFC 2.2 gpm for 3/4"	
	V3162-027	DLFC 2.7 gpm for 3/4"	
	V3162-032	DLFC 3.2 gpm for 3/4"	
	V3162-042	DLFC 4.2 gpm for 3/4"	
	V3162-053	DLFC 5.3 gpm for 3/4"	
	V3162-065	DLFC 6.5 gpm for 3/4"	
	V3162-075	DLFC 7.5 gpm for 3/4"	
	V3162-090	DLFC 9.0 gpm for 3/4"	
V3162-100	DLFC 10.0 gpm for 3/4"		

\*4 and 6 can be ordered as a complete assembly:  
V3331 Drain Elbow and Retainer Assembly

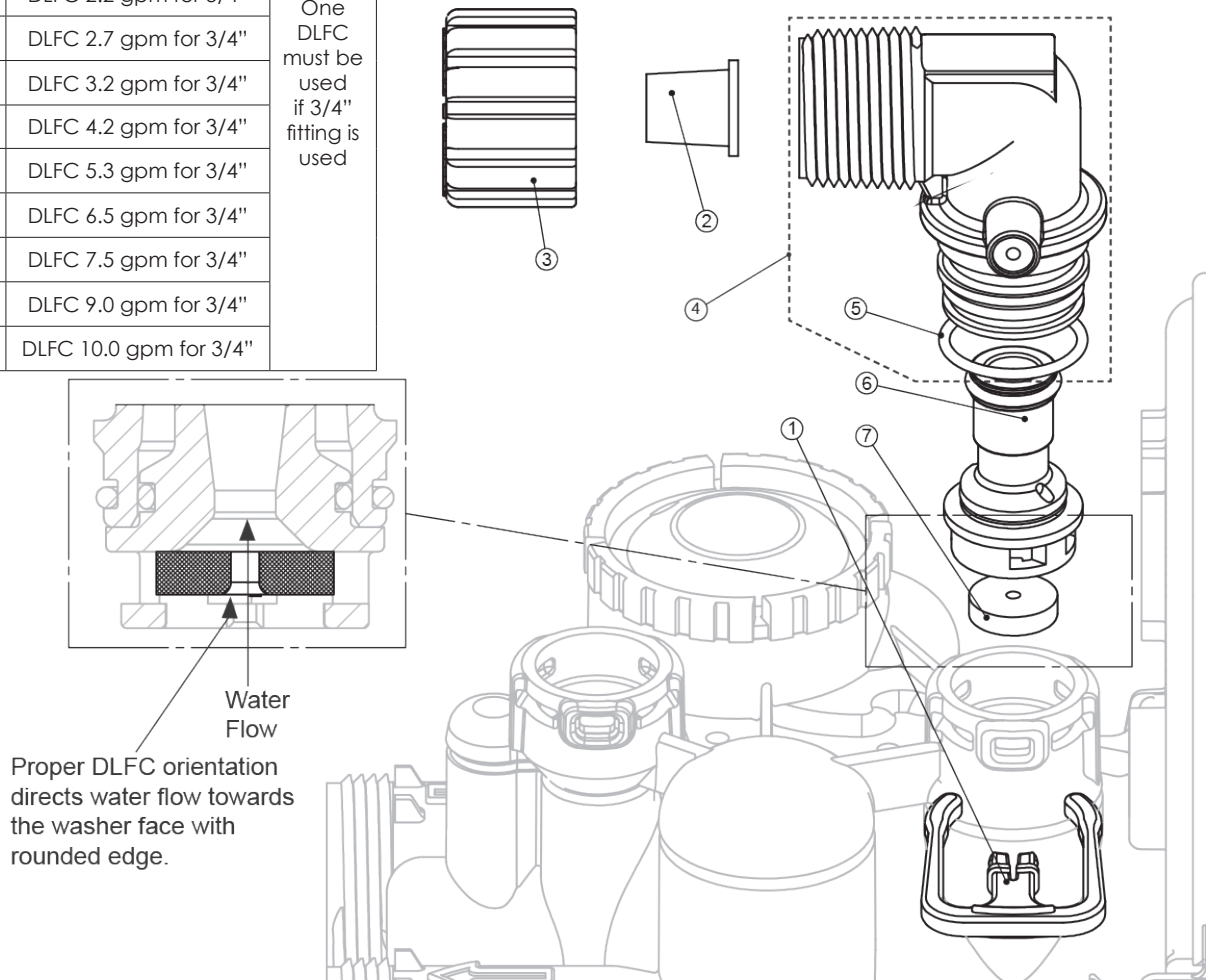

**DO NOT use pipe dope or other sealants on threads. Teflon tape must be used on threads of 3/4" NPT connection (unless using 5/8" polytubing).**

**DO NOT use Vaseline, oils, other hydrocarbon lubricants or spray silicone anywhere. A silicone lubricant may be used on black o-rings but is not necessary.**

# Parts Diagrams

## Drain Line - 1"

Drawing No.	Order No.	Description	Qty
1	H4615	Elbow Locking Clip	1
2	V3008-02	Drain FTG 1" Straight	1
3*	V3166	Drain FTG Body 1"	1
4*	V3167	Drain FTG Adapter 1"	1
5*	V3163	O-Ring 019	1
6*	V3150	Split Ring	1
7*	V3151	Nut 1" QC	1
8*	V3105	O-Ring 215	1
9	V3190-090	DLFC 9.0 gpm for 1"	One DLFC must be used if 1" fitting is used.
	V3190-100	DLFC 10.0 gpm for 1"	
	V3190-110	DLFC 11.0 gpm for 1"	
	V3190-130	DLFC 13.0 gpm for 1"	
	V3190-150	DLFC 15.0 gpm for 1"	
	V3190-170	DLFC 17.0 gpm for 1"	
	V3190-200	DLFC 20.0 gpm for 1"	
	V3190-250	DLFC 25.0 gpm for 1"	

\* Can be ordered as a set. Order number V3008-02, description: Drain FTG 1" Straight.

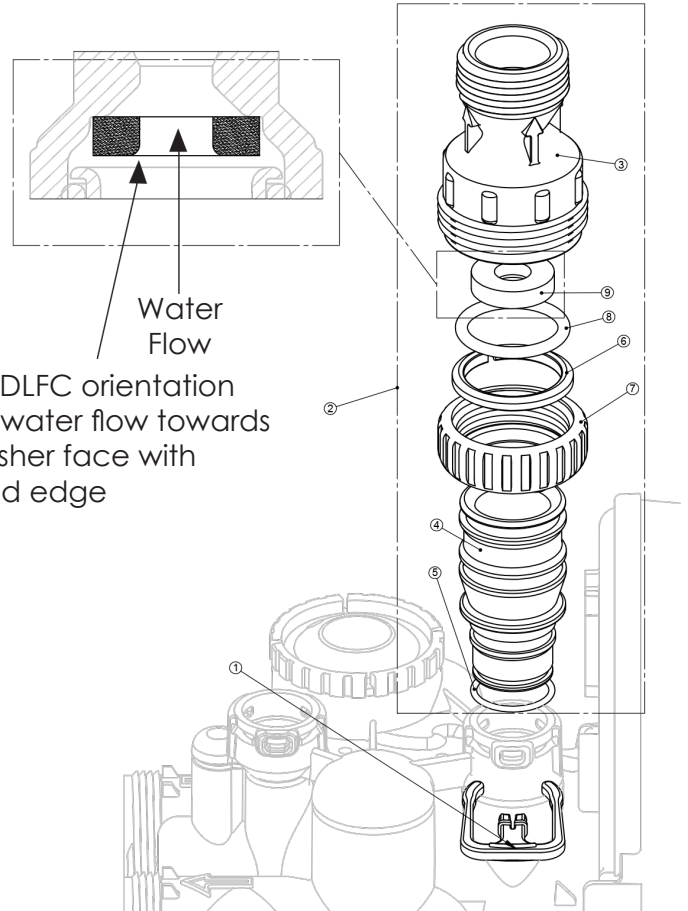

**DO NOT use pipe dope or other sealants on threads. Teflon tape must be used on threads of 1" NPT connection.**

**DO NOT use Vaseline, oils, other hydrocarbon lubricants or spray silicone anywhere. A silicone lubricant may be used on black o-rings, but is not necessary.**

# Installation Fitting Assemblies

Order No: **V3007-05**

Description: **Fitting 1-1/4" Plastic Male NPT Assembly**

Drawing No.	Order No.	Description	Quantity
1	V3176	Nut 1" Quick Connect	2
2	V3152	Split Ring	2
3	V3177	O-Ring 215	2
4	V3010	Fitting 1-1/4" Plastic Male NPT	2

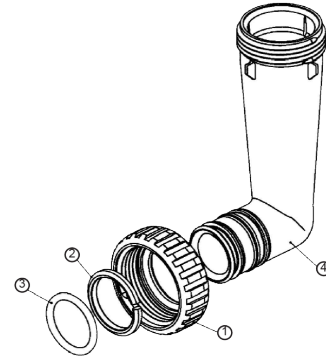
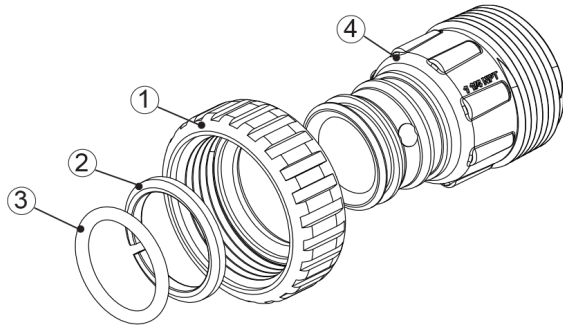

Order No: **V3191-01 (Optional)**

Description: **Fitting Vertical Adapter Assembly**

Drawing No.	Order No.	Description	Quantity
1	V3151	Nut 1" Quick Connect	2
2	V3150	Split Ring	2
3	V3105	O-Ring 215	2
4	V3191	Vertical Adapter	2



**DO NOT use pipe dope or other sealants on threads. Teflon tape must be used on threads of 1" NPT connection.**

**DO NOT use Vaseline, oils, other hydrocarbon lubricants or spray silicone anywhere. A silicone lubricant may be used on black o-rings but is not necessary.**

## Bypass Valve

Drawing No.	Order No.	Description	Quantity
1	V3176	Nut 1" Quick Connect	2
2	V3152	Split Ring	2
3	V3177	O-Ring 215	2
4	V3010	Fitting 1-1/4" Plastic Male NPT	2
5	V3146	Bypass Cap	2
6	V3147	Bypass Handle	2
7	V3148	Bypass Rotor Seal Retainer	2
8	V3152	O-Ring 135	2
9	V3155	O-Ring 112	2
10	V3156	O-Ring 214	2

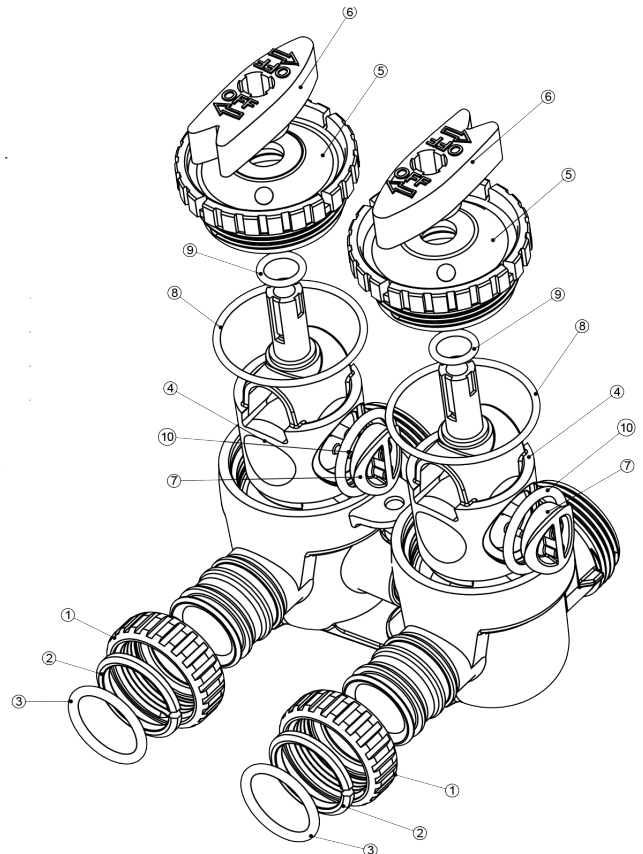

# Optional Installation Fitting Assemblies

Order No: **V3007-01**

Description: **Fitting ¾" & 1" PVC Solvent 90° Assembly**

Drawing No.	Order No.	Description	Quantity
1	V3151	Nut 1" Quick Connect	2
2	V3150	Split Ring	2
3	V3105	O-Ring 215	2
4	V3189	Fitting ¾" & 1" PVC Solvent 90°	2

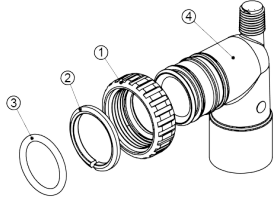

Order No: **V3007-02**

Description: **Fitting 1" Brass Sweat Assembly [Do NOT Install in California]**

Drawing No.	Order No.	Description	Quantity
1	V3151	Nut 1" Quick Connect	2
2	V3150	Split Ring	2
3	V3105	O-Ring 215	2
4	V3188	Fitting 1" Brass Sweat Assembly	2

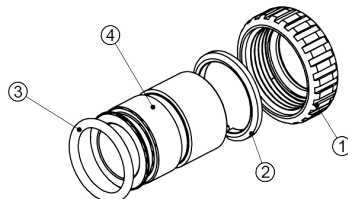

Order No: **V3007-03**

Description: **Fitting ¾" Brass Sweat Assembly [Do NOT Install in California]**

Drawing No.	Order No.	Description	Quantity
1	V3151	Nut 1" Quick Connect	2
2	V3150	Split Ring	2
3	V3105	O-Ring 215	2
4	V3188-01	Fitting ¾" Brass Sweat Assembly	2

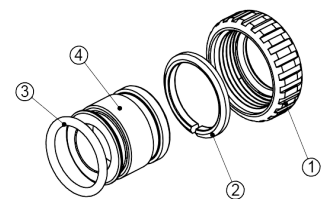

Order No: **V3007-04**

Description: **Fitting 1" Plastic Male NPT Assembly**

Drawing No.	Order No.	Description	Quantity
1	V3151	Nut 1" Quick Connect	2
2	V3150	Split Ring	2
3	V3105	O-Ring 215	2
4	V3164	Fitting 1" Plastic Male NPT	2

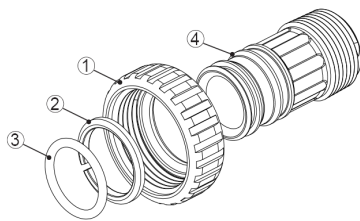

Order No: **V3007-05**

Description: **Fitting 1¼" Plastic Male NPT Assembly**

Drawing No.	Order No.	Description	Quantity
1	V3151	Nut 1" Quick Connect	2
2	V3150	Split Ring	2
3	V3105	O-Ring 215	2
4	V3317	Fitting 1¼" Plastic Male NPT	2

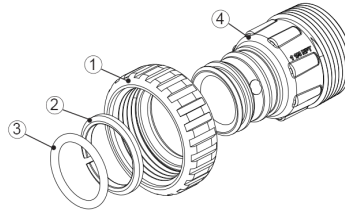

Order No: **V3007-07**

Description: **Fitting 1¼" & 1½" PVC Solvent Assembly**

Drawing No.	Order No.	Description	Quantity
1	V3151	Nut 1" Quick Connect	2
2	V3150	Split Ring	2
3	V3105	O-Ring 215	2
4	V3352	Fitting 1¼" & 1½" PVC Solvent	2

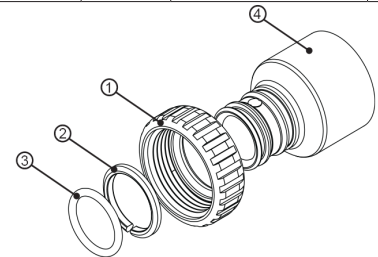

Order No: **V3007-09**

Description: **Fitting 1¼" & 1½" Brass Sweat Assembly**

Drawing No.	Order No.	Description	Quantity
1	V3151	Nut 1" Quick Connect	2
2	V3150	Split Ring	2
3	V3105	O-Ring 215	2
4	V3375	Fitting 1¼" & 1½" Brass Sweat	2

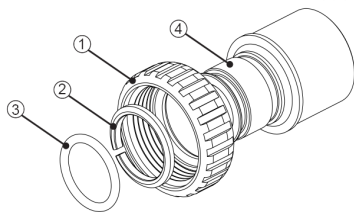

Order No: **V3007-12**

Description: **Fitting ¾" Brass SharkBite Assembly**

Drawing No.	Order No.	Description	Quantity
1	V3151	Nut 1" Quick Connect	2
2	V3150	Split Ring	2
3	V3105	O-Ring 215	2
4	V3628	Fitting ¾" Brass SharkBite	2

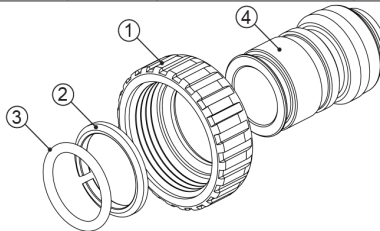

Order No: **V3007-13**

Description: **Fitting 1" Brass SharkBite Assembly**

Drawing No.	Order No.	Description	Quantity
1	V3151	Nut 1" Quick Connect	2
2	V3150	Split Ring	2
3	V3105	O-Ring 215	2
4	V3164	Fitting 1" Brass SharkBite	2

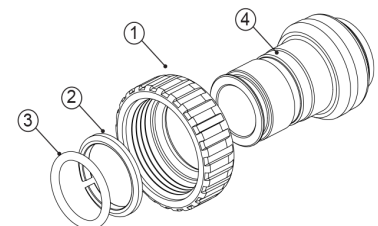

Order No: **V3007-15**

Description: **WS1 FTG ¾" JG QC 90° Assembly**

Drawing No.	Order No.	Description	Quantity
1	V3151	Nut 1" Quick Connect	2
2	V3150	Split Ring	2
3	V3105	O-Ring 215	2
4	V3790	Fitting ¾" QC with Stem 90°	2

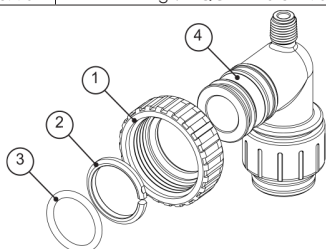

Order No: **V3007-17**

Description: **WS1 FTG 1" JG QC Assembly**

Drawing No.	Order No.	Description	Quantity
1	V3105	O-Ring 215	2
2	V3150	Split Ring	2
3	V3151	Nut 1" Quick Connect	2
4	V4045	Fitting 1" QC	2

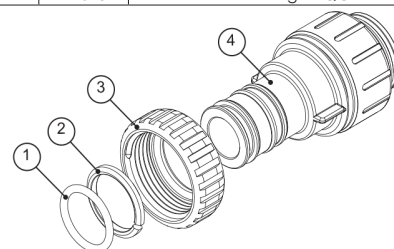

---

# Service Instructions

## DRIVE ASSEMBLY

Remove the valve cover to access the drive assembly.

**Disconnect the power source plug (black wire) from the PC board prior to disconnecting the motor or water meter plugs from the PC board.** The power source plug connects to the four-pin jack. The motor plug connects to the two-pin jack on the left-hand side of the PC board. The water meter plug (gray wire) connects to the three-pin jack on the far right-hand side of the PC board.

**The PC board can be removed separately from the drive bracket, but it is not recommended. Do NOT attempt to remove the display panel from the PC board.** Handle the board by the edges. To remove the PC board from the drive bracket, unplug the power, water meter and motor plugs from the PC board. Lift the middle latch along the top of the drive bracket while pulling outward on the top of the PC board. The drive bracket has two plastic pins that fit into the holes on the lower edge of the PC board. Once the PC board is tilted about 45° from the drive bracket, it can be lifted off of these pins. To reinstall the PC board, position the lower edge of the PC board so that the holes in the PC board line up with the plastic pins. Push the top of the PC board towards the valve until it snaps under the middle latch and then weave the power and water meter wires into the holders and reconnect the motor, water meter, and power plugs.

**The drive bracket must be removed to access the drive cap assembly and pistons or the drive gear cover. It is not necessary to remove the PC board from the drive bracket to remove the drive bracket.** To remove the drive bracket, start by removing the plugs for the power source and the water meter. Unweave the wires from the side holders. Two tabs on the top of the drive back plate hold the drive bracket in place. Simultaneously lift the two tabs and gently ease the top of the drive bracket forward. The lower edge of the drive bracket has two notches that rest on the drive back plate. Lift up and outward on the drive bracket to disengage the notches.

To reassemble, seat the bottom of the drive bracket so the notches are engaged at the bottom of the drive back plate. Push the top of the drive bracket toward the two latches. The drive bracket may have to be lifted slightly to let the threaded piston rod pass through the hole in the drive bracket. Maintain a slight engaging force on top of the drive bracket while deflecting the bracket slightly to the left by pressing on the side of the upper right corner. This helps the drive gears mesh with the drive cap assembly. The drive bracket is properly seated when it snaps under the latches on the drive back plate. **If resistance is felt before latching, then notches are not fully engaged, the piston rod is not in its hole, the wires are jammed between the drive bracket and drive back plate, or the gear is not engaging the drive cap assembly.**

To inspect the drive gears, the drive gear cover needs to be removed. Before trying to remove the gear cover, the drive bracket must be removed from the drive back plate. (Refer to the instructions above regarding removing the drive bracket from the drive back plate. The drive gear cover can be removed from the drive bracket without removing the motor or the PC board.) The drive gear cover is held in place on the drive bracket by three clips. The largest of the three clips is always oriented to the bottom of the drive bracket. With the PC board facing up, push in and down on the large clip on the drive gear cover. Handle the cover and the gears carefully so that the gears do not fall off the pegs in the cover.

Replace broken or damaged drive gears. **Do NOT lubricate any of the gears. Avoid getting any foreign matter on the reflective coating because dirt or oils may interfere with pulse counting.**

The drive gear cover only fits on one way: with the large clip oriented towards the bottom. If all three clips are outside of the gear shroud on the drive bracket, then the drive gear cover slips easily into place.

**The drive bracket does not need to be removed from the drive plate if the motor needs to be removed.** To remove the motor, disconnect the power and motor plugs from the jacks on the PC board. Move the spring clip loop to the right and hold. Rotate the motor at least a ¼ turn in either direction so the wires are vertical (up & down) before gently pulling on the wire connectors to remove the motor. **Pulling directly on the wires without rotating the motor may break the wires off the motor.**

---

# Service Instructions

Replace the motor if necessary. **DO NOT lubricate the motor or the gears.** To reinstall the motor, move the spring clip loop to the right and hold. Gently turn the motor while inserting so that the gear on the motor meshes with the gears under the drive gear cover. Release the spring clip loop and continue to rotate the motor until the wires are horizontal and the motor housing engages the small plastic bulge inside the drive bracket motor retainer. Reconnect the motor plug to the two-pronged jack on the lower left side of the PC board. If the motor will not easily engage with the drive gears when reinstalling, lift and slightly rotate the motor before reinserting.

Reconnect the power plug.

Replace the valve cover. After completing any valve maintenance involving the drive assembly or the drive cap assembly and pistons, unplug power source jack from the printed circuit board (black wire) and plug back in, or press and hold **NEXT** and **REGEN** buttons for 3 seconds.

This resets the electronics and establishes the service piston position. The display should display the software version and then reset the valve to the service position.

## DRIVE CAP ASSEMBLY, MAIN PISTON AND REGENERANT PISTON

The drive assembly must be removed to access the drive cap assembly. The drive cap assembly must be removed to access the piston(s). The drive cap assembly is threaded into the control valve body and seals with an o-ring. To remove the drive cap assembly, use the special plastic service spanner wrench (see page 29) or insert a ¼" to ½" flat blade screwdriver into one of the slots around the top 2" of the drive cap assembly so it engages the notches molded into the drive back plate around the top 2" of the piston cavity. See figure below. The notches are visible through the holes. Lever the screwdriver so the drive cap assembly turns counter clockwise. Once loosened, unscrew the drive cap assembly by hand and pull straight out.

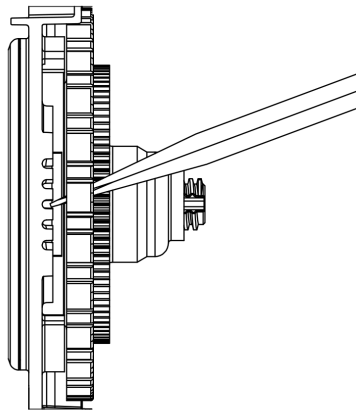



The drive cap assembly contains the drive cap, the main drive gear, drive cap spline, piston rod, and various other parts that should not be disassembled in the field. **The only replaceable part on the drive cap assembly is the o-ring.** Attached to the drive cap assembly is the main piston and regenerant piston.

The regenerant piston (the small diameter one behind the main piston) is removed from the main piston by pressing sideways and unsnapping it from its latch. Chemically clean in ProGuard, dilute sodium bisulfite or vinegar, or replace the regenerant piston if needed. To remove the main piston, fully extend the piston rod and then unsnap the main piston from its latch by pressing on the side with the number. Chemically clean in ProGuard, dilute sodium bisulfite or vinegar, or replace the main piston.

Reattach the main piston to the drive cap assembly. Reattach the regenerant piston (if needed) to the main piston. Reinsert the drive cap assembly and piston into the spacer stack assembly and hand tighten the drive cap assembly. Continue to tighten the drive cap assembly using a screwdriver as a ratchet until the black o-ring on the spacer stack assembly is no longer visible through the drain port. **Excessive force can break the notches molded into the drive back plate. Make certain that the main drive gear still turns freely. The exact position of the piston is not important as long as the main drive gear turns freely.**

---

# Service Instructions

Reattach the drive assembly to the control valve and connect all plugs. After completing any valve maintenance involving the drive assembly or the drive cap assembly and pistons, unplug power source jack from the printed circuit board (black wire) and plug back in or press and hold  and  buttons for 3 seconds.

This resets the electronics and establishes the service piston position. The display should flash the software version and then reset the valve to the service position.

## REFILL FLOW CONTROL ASSEMBLY:

To clean or replace the refill flow control, pull out the elbow-locking clip and then pull straight up on the elbow. Replace the elbow locking clip in the slot so that it is not misplaced. Twist and pull to remove the white flow control retainer. The flow control can be removed by prying upward through the side slots of the retainer with a small flat blade screwdriver.

Chemically clean the flow control or the white flow control retainer using dilute sodium bisulfite or vinegar. Do NOT use a wire brush. If necessary, replace the flow control, o-ring on the flow control retainer, or the o-ring on the elbow.

Reset the flow control so the rounded end is visible in the flow control. Reset the white flow control retainer by pushing the retainer into the elbow until the o-ring seats. Remove locking clip, push down on elbow to reset, and insert the locking clip.



**Do NOT use Vaseline, oils, or other unacceptable lubricants on o-rings. A silicone lubricant may be used on the o-ring on the elbow or the white retainer.**

## SPACER STACK ASSEMBLY (refer to diagrams on page 31):

To access the spacer stack assembly, remove the drive assembly, drive cap assembly, and piston. The spacer stack assembly can be removed easily without tools by using thumb and forefinger. Inspect the black o-rings and clear lip seals for wear or damage. Replace the entire stack if necessary. Do NOT disassemble the stack.

The spacer stack assembly may be chemically cleaned (dilute sodium bisulfite or vinegar) or wiped with a soft cloth.

The spacer stack assembly can be pushed into the control valve body bore by hand. Since the spacer stack assembly can be compressed, it is easier to use a blunt object (5/8" to 1-1/8" in diameter) to push the center of the assembly into the control valve body. The assembly is properly seated when at least four threads are exposed (approximately 5/8"). **Do NOT force the spacer stack assembly in. The control valve body bore interior can be lubricated with silicone to allow for easy insertion of the entire stack.**

Reattach the drive cap assembly and piston(s) and the drive assembly. After completing any valve maintenance involving the drive assembly or the drive cap assembly and pistons, unplug power source jack from the printed circuit board (black wire) and plug back in, or press and hold  and  buttons for 3 seconds.

This resets the electronics and establishes the service piston position. The display should flash the software version and then reset the valve to the service position.

## INJECTOR CAP, SCREEN, INJECTOR PLUG, AND INJECTOR (refer to page 33 for diagram):

Unscrew the injector cap and lift off. Loosen cap with special plastic service spanner wrench or pliers if necessary. Attached to the injector cap is a screen. Remove the screen and clean if fouled.

---Continued on Next Page---

---

# Service Instructions

The plug and/or injector can be pried out with a small screwdriver. The plug can be wiped clean. If the plug leaks, replace the entire plug. The injector consists of a throat and a nozzle. Chemically clean the injector with vinegar or sodium bisulfite. The holes can be blown out with air. Both pieces have small diameter holes that control the flow rates of water to insure that the proper concentration of regenerant is used. **Sharp objects, which can score the plastic, should NOT be used to clean the injector.** Scoring the injector or increasing the diameter of the hole could change the operating parameters of the injector.

Replace the screen and hand tighten the injector cap.

## WATER METER

The water meter assembly is connected to the PC board by a wire. If the entire water meter assembly is to be replaced, remove the control valve cover and disconnect the power source and water meter plugs from the PC board. Unlatch the drive assembly and lean it forward. Unthread the water meter wire from the side of the drive assembly and through the drive back plate. To reinstall, rethread the water meter wire through the drive back plate and the side of the drive assembly. Reattach the drive assembly and the water meter and power plugs.



**THIS WATER METER SHOULD NOT BE USED AS THE PRIMARY MONITORING DEVICE FOR CRITICAL OR HEALTH EFFECT APPLICATIONS.**

The water meter wire does not need to be removed from the PC board if the water meter is only being inspected and cleaned. To remove the water meter assembly, unscrew the meter cap on the left side of the control valve. Pliers may be used to unscrew the nut if necessary.

With the nut removed, a slot at the top of the water meter is visible. Twist a flat blade screwdriver in the slot between the control valve body and the meter. When the meter is part way out, it is easy to remove the water meter from the housing. Once the water meter is removed from the control valve body, gently pull forward on the turbine to remove it from the shaft.

**DO NOT use a wire brush to clean the turbine.** Wipe with a clean cloth or chemically clean in dilute sodium bisulfite or vinegar. **The turbine can be immersed in the chemical. DO NOT immerse electronics.** If the turbine is scored or damaged or the bearings on the turbine are worn, replace the turbine.

**DO NOT lubricate the turbine shaft.** The turbine shaft bearings are prelubricated. **DO NOT use Vaseline, oils, or other unacceptable lubricants on the o-ring. A silicone lubricant may be used on the black o-ring.**

Snap the turbine on the shaft and reinsert the water meter into the side slot. Hand tighten the nut. **DO NOT use a pipe wrench to tighten nut.**

# System Troubleshooting Guidelines

These troubleshooting guidelines are not intended to be an all-inclusive or to substitute the expert diagnosis of your local Certified Water Professional.

## Hard (Untreated) Water to Service

Cause	Solution
Open or defective bypass	Close or verify bypass
Loss of media	Refer to problem "Loss of media"
Unit fails to regenerate	Refer to problem "System Fails to Regenerate"
Valve fails to draw brine (not using any salt)	Refer to problem "System Fails to Draw Brine"
Decreasing exchange capacity of resin	Clean or replace resin bed
No salt in brine tank	Add salt
Leak at riser tube	Verify that riser tube is seated correctly and is not damaged by heat or high water pressure
ProGuard supply exhausted	Refill ProGuard feeder

## System Fails to Regenerate

Cause	Solution
Faulty electrical supply	Verify electrical service Confirm unswitched power outlet
Obstructed flow meter	Clean and/or replace flow meter
Damaged PCB	Replace PCB
Damaged drive motor	Replace drive motor

# System Troubleshooting Guidelines

## Loss of Water Pressure

Cause	Solution
Mineral or iron build-up in resin tank	Clean resin bed and control valve; increase regeneration frequency; increase ProGuard dosage rate
Plugged lower and/or upper distributor	Verify that distributors are free of debris
Crushed lower and/or upper distributor	Replace distributor(s) - Check for adequate temperature/pressure protection
Resin damaged due to natural attrition or chlorine/chloramine oxidation	Replace resin

## System Runs Continually Down the Drain

Cause	Solution
Piston stuck in brine/rinse or backwash position	Inspect drivetrain and perform remedial action
Damaged seals/spacers	Inspect seals/spacers and perform remedial action
Damaged piston	Inspect drivetrain and perform remedial action

## Loss of Media Through Drain Line or Plumbing

Cause	Solution
Lower and/or upper distributor damaged	Replace distributor(s)
Leak between riser tube and upper distributor	Verify that riser tube is seated correctly and is not cracked
Heat and/or Pressure Damage	Inspect pressure regulating valve and hot water backup protection devices. Perform appropriate remedial action

# System Troubleshooting Guidelines

## System Fails to Draw Brine

Cause	Solution
Low operating pressure	Verify operating pressure; must exceed 30 psi dynamic
Plugged injector	Clean injector
Plugged injector filter	Clean injector filter
Piston stuck in incorrect position	Inspect drivetrain and perform remedial action
Restricted/obstructed drain line	Check drain line for kinks, restrictions, or obstructions
Restricted/obstructed brine line	Check brine line for kinks, restrictions, or obstructions
Leak in brine line	Verify brine line and connections for air leakage
Insufficient water in brine tank	Refer to problem "System fails to refill brine tank"

## Excessive Water in Brine Tank

Cause	Solution
System fails to draw brine	Refer to problem "System fails to draw brine"
Improper brine refill time setting	Verify that brine refill time corresponds to the proper salt level and amount of ion exchange resin and other media
Missing brine refill flow control	Verify that flow control is installed and properly sized
Leak from valve to brine tank	Clean or replace brine valve
Brine valve damaged	Replace brine valve

# System Troubleshooting Guidelines

## System Uses Too Much Salt

Cause	Solution
Excessive water in brine tank	Refer to problem "Excessive Water in Brine Tank"
System cleaning frequently	Check household for excessive or unexpected water usage (e.g. leaky toilet fill valves, T&P relief drainage, Reverse Osmosis processors, humidifiers, plumbing leaks, etc).

## Salty Water to Service

Cause	Solution
Excessive water in brine tank	Refer to problem "Excessive water in brine tank"
Injector undersized	Verify injector selection
Injector fouled	Remove and clean injector
Improper brine/slow rinse time setting	Verify that brine/slow rinse time corresponds to the proper salt level and amount of resin
Improper fast rinse time setting	Verify that fast rinse time corresponds to the proper salt level and amount of resin

## System Fails to Refill Brine Tank

Cause	Solution
Improper brine refill time setting	Verify that refill time corresponds to salt level and amount of resin
Plugged refill flow control	Clean flow control

# Troubleshooting Procedures

Problem	Possible Cause	Solution
<b>1. Timer does not display time of day.</b>	<ul style="list-style-type: none"> <li>a. Transformer unplugged</li> <li>b. No electric power at outlet</li> <li>c. Defective transformer</li> <li>d. Defective PC board</li> </ul>	<ul style="list-style-type: none"> <li>a. Connect power</li> <li>b. Repair outlet or use working outlet</li> <li>c. Replace transformer</li> <li>d. Replace PC board</li> </ul>
<b>2. Timer does not display correct time of day.</b>	<ul style="list-style-type: none"> <li>a. Switched outlet</li> <li>b. Power outage</li> <li>c. Defective PC board</li> </ul>	<ul style="list-style-type: none"> <li>a. Use uninterrupted outlet</li> <li>b. Reset time of day</li> <li>c. Replace PC board</li> </ul>
<b>3. No softening/filtering display when water is flowing.</b>	<ul style="list-style-type: none"> <li>a. Bypass valve in bypass position</li> <li>b. Meter connection disconnected</li> <li>c. Restricted/stalled meter turbine</li> <li>d. Defective meter</li> <li>e. Defective PC board</li> </ul>	<ul style="list-style-type: none"> <li>a. Put bypass valve in service position</li> <li>b. Connect meter to PC board</li> <li>c. Remove meter and check for rotation or foreign material</li> <li>d. Replace meter</li> <li>e. Replace PC board</li> </ul>
<b>4. Control valve regenerates at wrong time of day.</b>	<ul style="list-style-type: none"> <li>a. Power outages</li> <li>b. Time of day not set correctly</li> <li>c. Time of regeneration incorrect</li> <li>d. Control valve set at "on O" (immediate regeneration)</li> <li>e. Control valve set at NORMAL + O</li> </ul>	<ul style="list-style-type: none"> <li>a. Reset control valve to correct time of day</li> <li>b. Reset to correct time of day</li> <li>c. Reset regeneration time</li> <li>d. Check control valve set-up procedure regeneration time option</li> <li>e. Check control valve set-up procedure regeneration time option</li> </ul>
<p><b>5. ERROR followed by Code number:</b></p> <p><b>Error Code 101</b>- Unable to recognize start of regeneration</p> <p><b>Error Code 102</b> - Unexpected stall</p> <p><b>Error Code 103</b> - Motor ran too long; timed out trying to reach next cycle position</p> <p><b>Error Code 104</b> - Motor ran too long; timed out trying to reach home position</p> <p><b>If other Error Codes display, contact the factory.</b></p>	<ul style="list-style-type: none"> <li>a. Control valve has just been serviced</li> <li>b. Foreign matter is lodged in control valve</li> <li>c. High drive forces on piston</li> <li>d. Control valve piston not in home position</li> <li>e. Motor not inserted fully to engage pinion, motor wires broken or disconnected, motor failure</li> <li>f. Drive gear label dirty or damaged, missing or broken gear</li> <li>g. Drive bracket incorrectly aligned to back plate</li> <li>h. PC board is damaged or defective</li> <li>i. PC board incorrectly aligned to drive bracket</li> </ul>	<ul style="list-style-type: none"> <li>a. Press NEXT and REGEN for 3 seconds or unplug power source jack (black wire) and plug back in to reset control valve</li> <li>b. Check piston and spacer stack assembly for foreign matter</li> <li>c. Replace piston(s) and spacer stack assembly</li> <li>d. Press NEXT and REGEN for 3 seconds or unplug power source jack (black wire) and plug back in to reset control valve</li> <li>e. Check motor and wiring. Replace motor if necessary. Replace or clean drive gear.</li> <li>f. Replace or clean drive gear</li> <li>g. Reset drive bracket properly</li> <li>h. Replace PC board</li> <li>i. Ensure PC board is correctly snapped onto drive bracket</li> </ul>

# Troubleshooting Procedures

Problem	Possible Cause	Solution
<b>6. Control valve stalled in regeneration.</b>	<ul style="list-style-type: none"> <li>a. Motor not operating</li> <li>b. No electric power at outlet</li> <li>c. Defective transformer</li> <li>d. Defective PC board</li> <li>e. Broken drive gear or drive cap assembly</li> <li>f. Broken piston retainer</li> <li>g. Broken main or regenerant piston</li> </ul>	<ul style="list-style-type: none"> <li>a. Replace motor</li> <li>b. Repair outlet or use working outlet</li> <li>c. Replace transformer</li> <li>d. Replace PC board</li> <li>e. Replace drive gear or drive cap assembly</li> <li>f. Replace drive cap assembly</li> <li>g. Replace main or regenerant piston</li> </ul>
<b>7. Control valve does not regenerate automatically when REGEN button is depressed and held.</b>	<ul style="list-style-type: none"> <li>a. Transformer unplugged</li> <li>b. No electric power at outlet</li> <li>c. Broken drive gear or drive cap assembly</li> <li>d. Defective PC board</li> </ul>	<ul style="list-style-type: none"> <li>a. Connect transformer</li> <li>b. Repair outlet or use working outlet</li> <li>c. Replace drive gear or drive cap assembly</li> <li>d. Replace PC board</li> </ul>
<b>8. Control valve does not regenerate automatically but does when REGEN button is depressed.</b>	<ul style="list-style-type: none"> <li>a. Bypass valve in bypass position</li> <li>b. Meter connection disconnected</li> <li>c. Restricted/stalled meter turbine</li> <li>d. Defective meter</li> <li>e. Defective PC board</li> <li>f. Set-up error</li> </ul>	<ul style="list-style-type: none"> <li>a. Put control valve in service option</li> <li>b. Connect meter to PC board</li> <li>c. Remove meter and check for rotation or foreign matter</li> <li>d. Replace meter</li> <li>e. Replace PC board</li> <li>f. Check control valve se-up procedure</li> </ul>
<b>9. Time of day flashes on and off.</b>	<ul style="list-style-type: none"> <li>a. Power has been out for more than two hours, the transformer was unplugged and then plugged back into wall outlet, the transformer plug was unplugged and then plugged back into the board or the NEXT and REGEN buttons were pressed to reset the valve.</li> </ul>	<ul style="list-style-type: none"> <li>a. Reset the time of day</li> </ul>

---

# Statement Of Limited Product Warranty

**1st year of ownership** This residential water system is warranted as to workmanship and material for a period of one year from date of original installation at the original installation site, if properly installed by a Certified Installer. Should any component in your system prove defective in the first year, it will be repaired, rebuilt or replaced at our option, provided it is returned directly to us.

**After the 1st year of ownership, and for 5 more years:** should any component in your system prove defective, it will be repaired, rebuilt or replaced at our option for a maximum charge of \$50.00, provided it is returned directly to us. Labor, transportation, shipping or other charges incurred in the diagnosis, replacement or repair of defective components are not covered by this warranty. If you choose not to send a defective component back to us, repairs to your system can be conducted in your home by a factory authorized service technician if your home is within the operating radius of an Authorized Repair Center. This warranty does not cover transportation, shipping, diagnosis, replacement and repair charges resulting from your in-home repair request. We will not be held responsible for loss or damage caused by any defective component.

**Conditions** This warranty must be presented at time of claim and all claims must be presented within 30 days of occurrence. This warranty is void if your water system is not installed in compliance with prevailing plumbing codes, according to our installation protocol, or if the influent water temperature is hotter than 90°F or where the static water pressure is less than 25psi, or more than 75psi. Intentional/malicious damage, misuse, neglect, unauthorized modifications or accidental damage to the system is not covered by this warranty. This warranty does not cover damage caused by pressure surges, water hammer, power surges/sags, lightning, fire, flood, freezing, earthquake, terrorism, war, or other casualty.

**No Liability for Consequential Damages** Unless otherwise required by applicable law, we shall not be liable for any damages whatsoever (including without limitation, lost time, inconvenience, expenses such as telephone calls, labor or material charges incurred in connection with the removal or replacement of the part(s) or product(s), special, incidental, consequential, or indirect damages for personal injury, loss of business profits, business interruption, loss of business information, or any other financial loss) arising out of the use of or inability to use the defective part(s) or product(s), even if we have been advised of the possibility of such damages. Our entire liability under any provision of this Limited Warranty shall be limited to the amount actually paid for the part(s) or product(s).

**No Other Warranties** We specifically disclaim all other warranties; either express or implied, including, but not limited to implied warranties of merchantability and fitness for a particular purpose, with regard to the part(s), product(s) and/or any accompanying written materials. This limited warranty gives you specific legal rights. You may have other rights that vary from state/jurisdiction to state/jurisdiction.

**Wear and Tear** Your water system is subject to normal wear and tear during its usable service life. Wear and tear is not regarded as a product defect and is not covered by this warranty.

**Periodic replacement of media** While built to the highest standards, certain media in your Water System will need to be replaced periodically by your local authorized service agent. Replacement intervals vary depending on your water chemistry and water consumption habits. Consult with your water specialist during your annual cleaning and disinfection service to ensure that you enjoy the very best water quality. Media replacement is not covered under this warranty.

**ProGuard Warranty Extension** Your water system includes a ProGuard dispensing system. ProGuard is so effective at protecting systems that we will extend your warranty by one more year for every year that you use ProGuard. Proof of Purchase is required when filing a claim.

In order for this warranty to be valid, you must be the original consumer purchaser, have purchased the water equipment from an authorized reseller, and provide a copy of the original purchase receipt with proof of purchase date and price.

**This limited warranty is only valid if registered within 10 days of initial installation.**

**If unregistered, this warranty is only valid for 1 year from the date of original manufacture.**

**Consult with your Local Clean Water Crusader on availability of Extended Warranties**

**Register Your Warranty Now at [www.CrusaderWater.com](http://www.CrusaderWater.com)**

# What is Hard Water Costing You?

Items Affected by Hard Water	Average Family Cost		Average Family Savings		Average % Saved
	Per Year	Per Month	Per Year	Per Month	
<b>Plumbing and Appliances</b> Replacement and repairs of pipes, faucets, washer, dishwasher, water heater, etc. <i>Water Quality Research Council Study</i>	\$181.20	\$15.10	\$135.90	\$11.32	75%
<b>Cooking and Coffee</b> Tea, sugar, canning, etc. <i>National Restaurant Association</i>	\$179.03	\$14.92	\$33.88	\$2.82	25%
<b>Personal Care Items</b> Slips, lingerie, etc. <i>American Laundry Institute</i>	\$91.87	\$7.66	\$27.54	\$2.30	30%
<b>Clothing and Linens</b> Washable items such as towels and linens <i>American Laundry Institute</i>	\$906.00	\$75.50	\$264.25	\$22.65	30%
<b>Energy Consumption</b> Heat loss due to scale <i>University of New Mexico and WQA Studies</i>	\$483.20	\$40.27	\$97.30	\$8.11	20%
<b>Soaps and Cleaning Aids</b> Laundry, cleaning, dishwashing, bathing, skin-care, shaving, shampoo, etc. <i>Orange County Consumer Survey (10+ hours of cleaning per month)</i>	\$1,558.32	\$129.86	\$1,168.74	\$97.39	75%

\*Original study was performed in 2009. Values have been adjusted for inflation using BLS CPI-U data for 2025.

# What Could Soft Water Be Saving You?

TOTAL COSTS AND SAVINGS		
	HARD WATER COST	SOFT WATER SAVINGS
<b>Total Per Day</b>	\$9.44	\$4.82
<b>Total Per Month</b>	\$283.32	\$144.60
<b>Total Per Year</b>	\$3,409.68	\$1,735.99
<b>Total Over 10 Years</b>	\$33,996.74	\$17,351.71
<i>The figures above are national average figures based up on a family size of 4 people with an average water hardness of 10 grains per gallon</i>		

\*Original study was performed in 2009. Values have been adjusted for inflation using BLS CPI-U data for 2025.